

**Features**

- Advanced high cell density Trench technology
- Super Low Gate Charge
- Excellent CdV/dt effect decline
- 100% EAS Guaranteed
- Green Device Available

**Applications**

- High Frequency Point-of-Load, Synchronous Buck Converter
- Networking DC-DC Power System
- Load Switch

**Product Summary**



$V_{DS}$	100	V
$I_D$	39	A
$R_{DS(ON)}$ (at $V_{GS}=10V$ )	20	m $\Omega$
$R_{DS(ON)}$ (at $V_{GS}=4.5V$ )	24	m $\Omega$

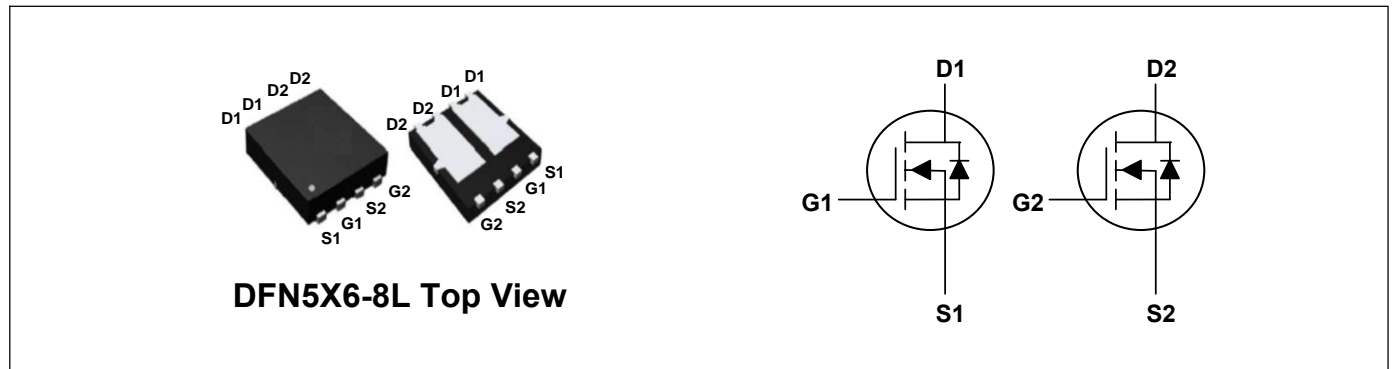

**Absolute Maximum Ratings ( $T_C=25^\circ C$ , unless otherwise noted)**

Parameter	Symbol	Rating	Units
Drain-Source Voltage	$V_{DS}$	100	V
Gate-Source Voltage	$V_{GS}$	$\pm 20$	V
Continuous Drain Current <sup>1</sup>	$I_D@T_C=25^\circ C$	39	A
Continuous Drain Current <sup>1</sup>	$I_D@T_C=100^\circ C$	24	A
Pulsed Drain Current <sup>2</sup>	$I_{DM}$	156	A
Single Pulse Avalanche Energy <sup>3</sup>	$E_{AS}$	64	mJ
Total Power Dissipation <sup>4</sup>	$P_D@T_C=25^\circ C$	59.5	W
Storage Temperature Range	$T_{STG}$	-55 to 150	$^\circ C$
Operating Junction Temperature Range	$T_J$	-55 to 150	$^\circ C$

**Thermal Characteristics**

Parameter	Symbol	Typ	Max	Unit
Thermal Resistance Junction-Ambient <sup>1</sup>	$R_{\theta JA}$	---	55	$^\circ C/W$
Thermal Resistance Junction-Case <sup>1</sup>	$R_{\theta JC}$	---	2.1	$^\circ C/W$

**Electrical Characteristics ( $T_J=25^{\circ}\text{C}$ , unless otherwise noted)**

Parameter	Symbol	Conditions	Min	Typ	Max	Unit
Drain-Source Breakdown Voltage	$BV_{DSS}$	$V_{GS}=0V, I_D=250\mu A$	100	---	---	V
Static Drain-Source On-Resistance <sup>2</sup>	$R_{DS(ON)}$	$V_{GS}=10V, I_D=20A$	---	15	20	m $\Omega$
		$V_{GS}=4.5V, I_D=10A$	---	18	24	m $\Omega$
Gate Threshold Voltage	$V_{GS(th)}$	$V_{GS}=V_{DS}, I_D=250\mu A$	1.0	---	2.5	V
Drain-Source Leakage Current	$I_{DSS}$	$V_{DS}=100V, V_{GS}=0V, T_J=25^{\circ}\text{C}$	---	---	1	$\mu A$
Gate-Source Leakage Current	$I_{GSS}$	$V_{GS}=\pm 20V, V_{DS}=0V$	---	---	$\pm 100$	nA
Forward Transconductance	$g_{fs}$	$V_{DS}=10V, I_D=20A$	---	35	---	S
Total Gate Charge	$Q_g$	$V_{DS}=50V, V_{GS}=10V, I_D=20A$	---	23	---	nC
Gate-Source Charge	$Q_{gs}$		---	3	---	
Gate-Drain Charge	$Q_{gd}$		---	5	---	
Turn-On Delay Time	$T_{d(on)}$	$V_{DD}=50V, V_{GS}=10V, R_G=3\Omega, I_D=20A$	---	8.6	---	ns
Rise Time	$T_r$		---	3.6	---	
Turn-Off Delay Time	$T_{d(off)}$		---	23	---	
Fall Time	$T_f$		---	48	---	
Input Capacitance	$C_{iss}$	$V_{DS}=50V, V_{GS}=0V, f=1\text{MHz}$	---	1182	---	pF
Output Capacitance	$C_{oss}$		---	142	---	
Reverse Transfer Capacitance	$C_{rss}$		---	9.5	---	

**Drain-Source Diode Characteristics**

Parameter	Symbol	Conditions	Min	Typ	Max	Unit
Diode Forward Voltage <sup>2</sup>	$V_{SD}$	$V_{GS}=0V, I_S=1A, T_J=25^{\circ}\text{C}$	---	---	1.2	V

**Note:**

- 1.The data tested by surface mounted on a 1 inch<sup>2</sup> FR-4 board with 2OZ copper.
- 2.The data tested by pulsed , pulse width  $\leq 300\mu s$  , duty cycle  $\leq 2\%$
- 3.The EAS data shows Max. rating . The test condition is  $V_{DD}=25V, V_{GS}=10V, L=0.5\text{mH}$
- 4.The power dissipation is limited by 150 $^{\circ}\text{C}$  junction temperature

**Typical Characteristics**

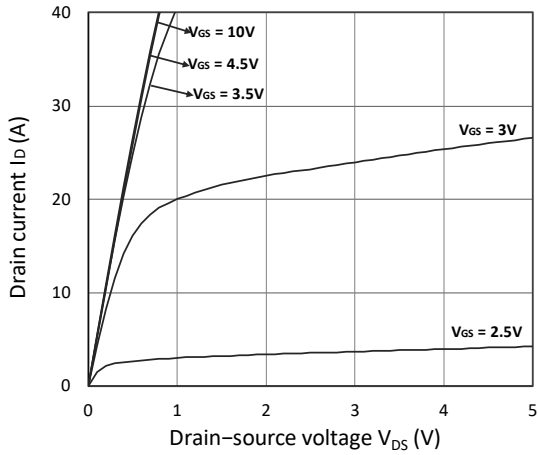

Figure 1. Output Characteristics

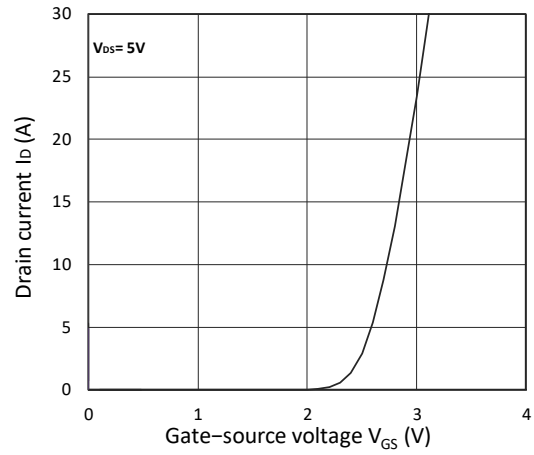

Figure 2. Transfer Characteristics

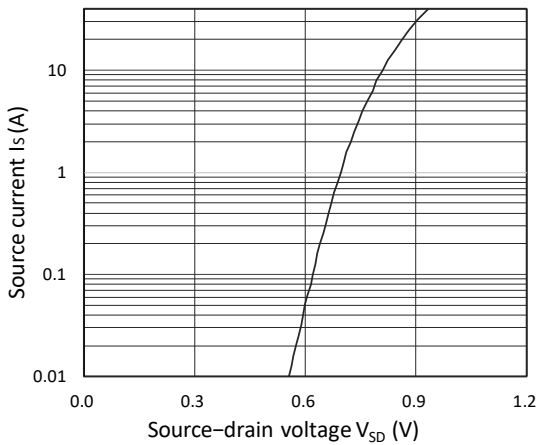

Figure 3. Forward Characteristics of Reverse

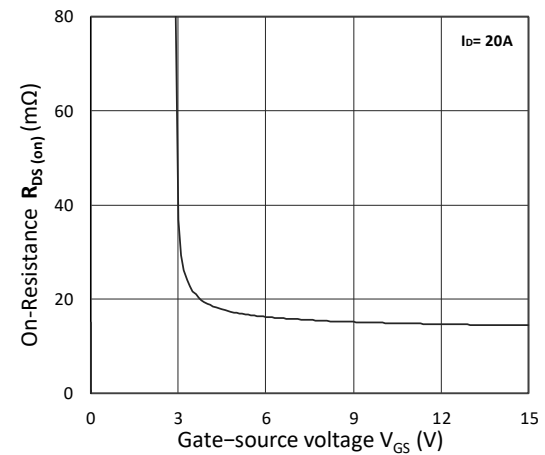

Figure 4.  $R_{DS(ON)}$  vs.  $V_{GS}$

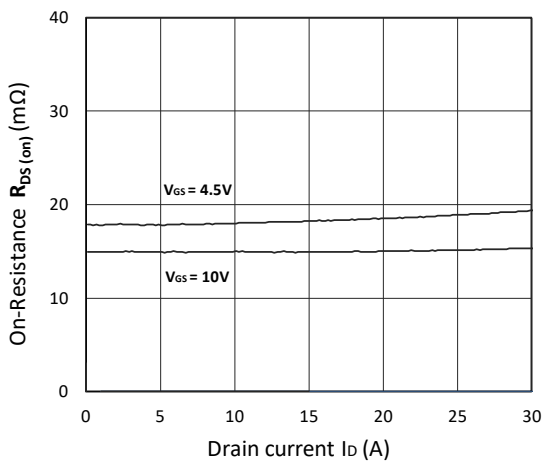

Figure 5.  $R_{DS(ON)}$  vs.  $I_D$

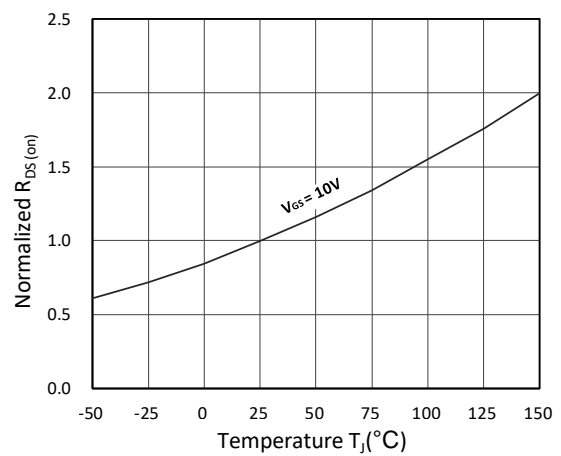

Figure 6. Normalized  $R_{DS(ON)}$  vs. Temperature

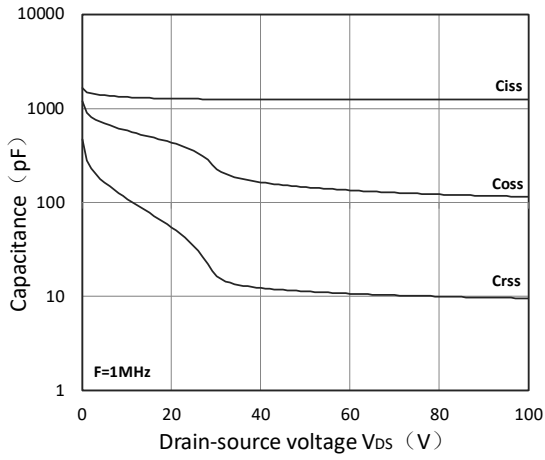

Figure 7. Capacitance Characteristics

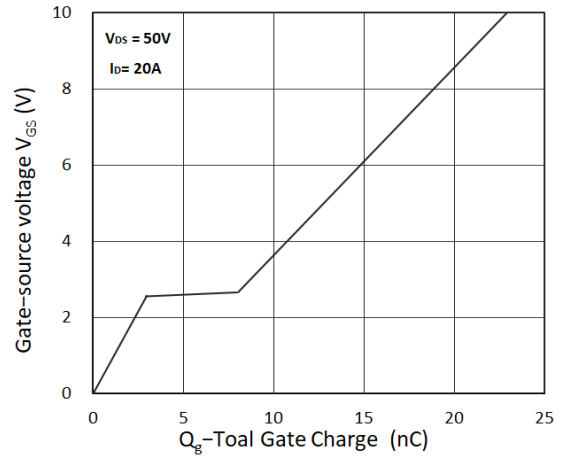

Figure 8. Gate Charge Characteristics

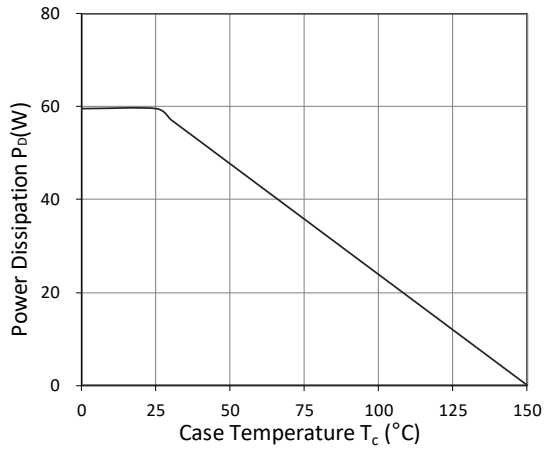

Figure 9. Power Dissipation

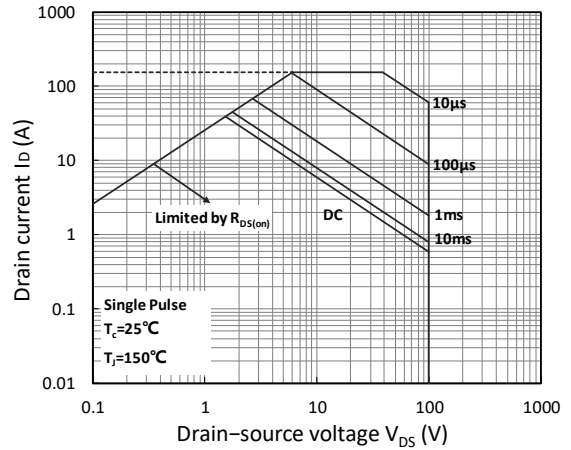

Figure 10. Safe Operating Area

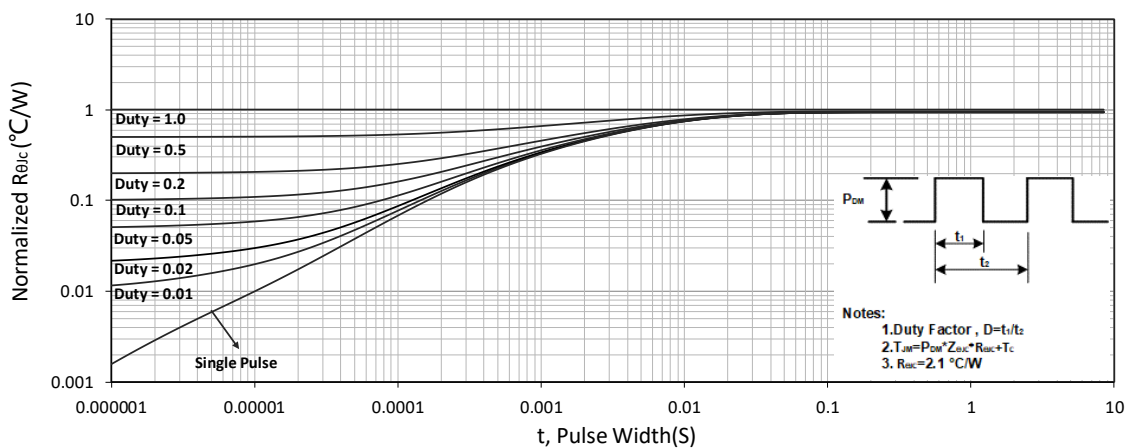
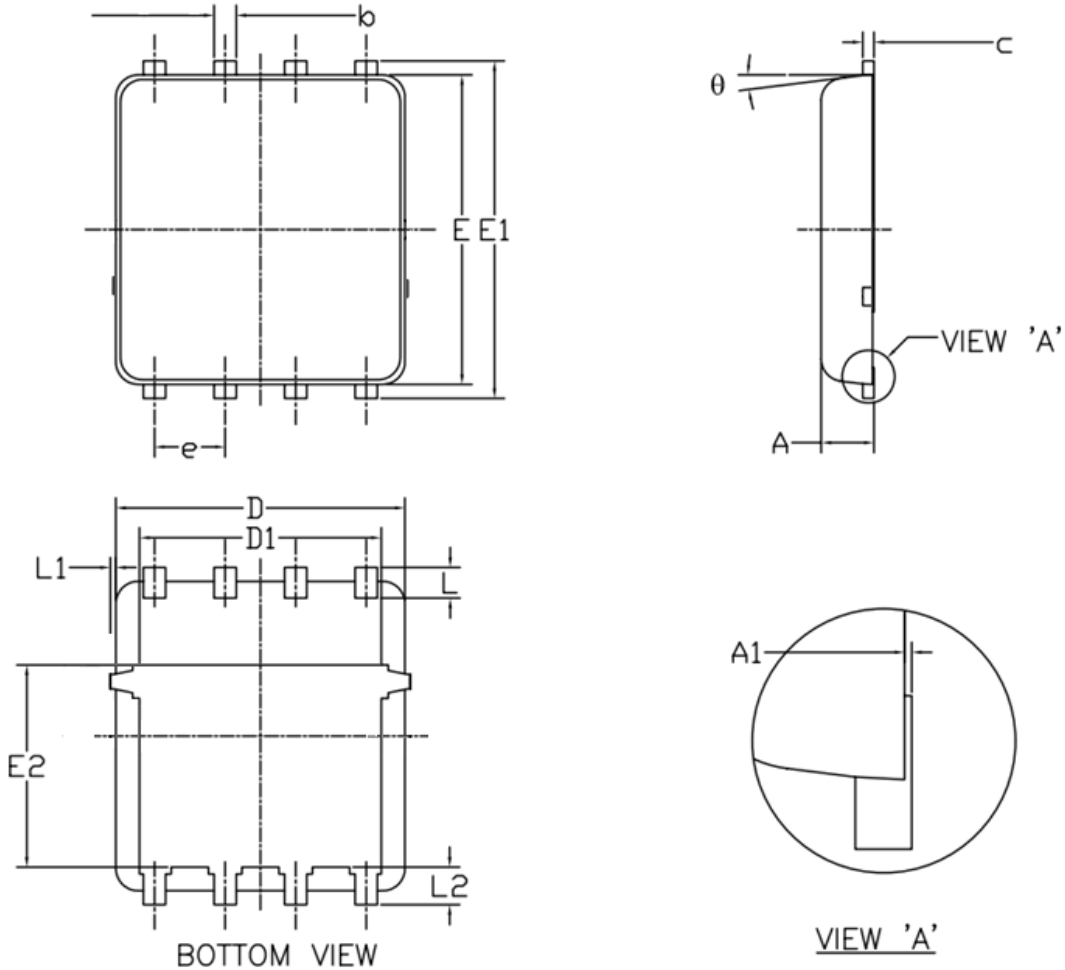

Figure 11. Normalized Maximum Transient Thermal Impedance

**DFN5X6-8L Package Outline Dimensions**



Symbol	Dimensions (unit:mm)			Symbol	Dimensions (unit:mm)		
	Min	Typ	Max		Min	Typ	Max
<b>A</b>	0.90	1.00	1.20	<b>E1</b>	5.90	6.10	6.35
<b>A1</b>	0.00	--	0.05	<b>E2</b>	3.38	3.58	3.92
<b>b</b>	0.30	0.40	0.51	<b>e</b>	1.27 BSC		
<b>c</b>	0.20	0.25	0.33	<b>L</b>	0.51	0.61	0.71
<b>D</b>	4.80	4.90	5.40	<b>L1</b>	--	--	0.15
<b>D1</b>	3.61	4.00	4.25	<b>L2</b>	0.41	0.51	0.61
<b>E</b>	5.65	5.80	6.06	<b>theta</b>	0°	--	12°