

Features

- Advanced high cell density Trench technology
- Super Low Gate Charge
- Excellent CdV/dt effect decline
- 100% EAS Guaranteed
- Green Device Available

Applications

- High Frequency Point-of-Load, Synchronous Buck Converter
- Networking DC-DC Power System
- Load Switch

Product Summary



V_{DS}	100	V
I_D	145	A
$R_{DS(ON)}$ Typ (at $V_{GS}=10V$)	3.8	m Ω

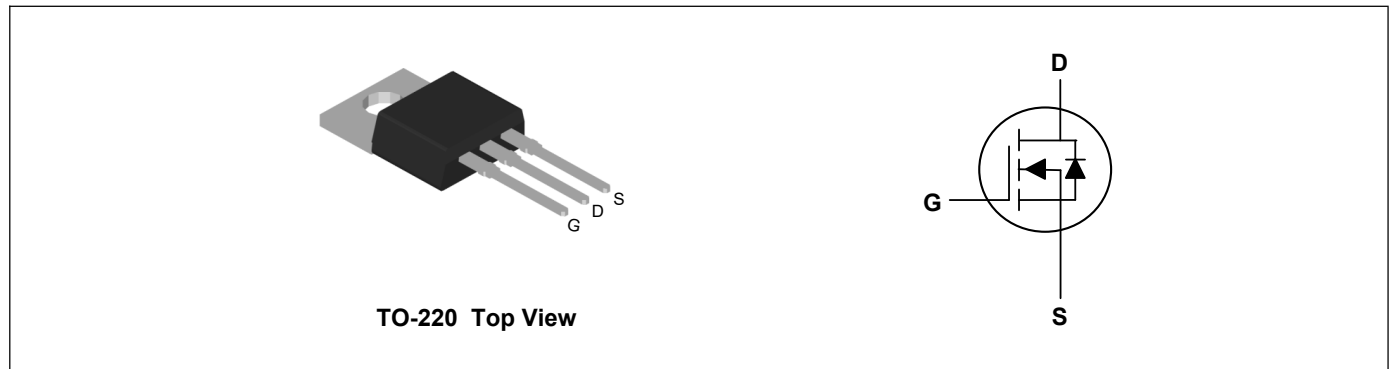

Absolute Maximum Ratings ($T_C=25^\circ\text{C}$, unless otherwise noted)

Parameter	Symbol	Rating	Units
Drain-Source Voltage	V_{DS}	100	V
Gate-Source Voltage	V_{GS}	± 20	V
Continuous Drain Current ¹	$I_D@T_C=25^\circ\text{C}$	145	A
Continuous Drain Current ¹	$I_D@T_C=100^\circ\text{C}$	92	A
Pulsed Drain Current ²	I_{DM}	580	A
Single Pulse Avalanche Energy ³	E_{AS}	320	mJ
Total Power Dissipation ⁴	P_D	208	W
Storage Temperature Range	T_{STG}	-55 to 150	$^\circ\text{C}$
Operating Junction Temperature Range	T_J	-55 to 150	$^\circ\text{C}$

Thermal Characteristics

Parameter	Symbol	Typ	Max	Unit
Thermal Resistance Junction-Ambient ¹	$R_{\theta JA}$	---	58	$^\circ\text{C}/\text{W}$
Thermal Resistance Junction-Case ¹	$R_{\theta JC}$	---	0.6	$^\circ\text{C}/\text{W}$

Electrical Characteristics (T_J=25°C, unless otherwise noted)

Parameter	Symbol	Conditions	Min	Typ	Max	Unit
Drain-Source Breakdown Voltage	BV _{DSS}	V _{GS} =0V, I _D =250uA	100	---	---	V
Static Drain-Source On-Resistance	R _{DS(ON)}	V _{GS} =10V, I _D =20A	---	3.8	4.5	mΩ
Gate Threshold Voltage	V _{GS(th)}	V _{GS} =V _{DS} , I _D =250uA	2.0	---	4.0	V
Drain-Source Leakage Current	I _{DSS}	V _{DS} =100V, V _{GS} =0V, T _J =25°C	---	---	1	uA
Gate-Source Leakage Current	I _{GSS}	V _{GS} =±20V, V _{DS} =0V	---	---	±100	nA
Gate Resistance	R _g	V _{DS} =0V, V _{GS} =0V, f=1MHz	---	1.3	---	Ω
Total Gate Charge	Q _g	V _{DS} =50V, V _{GS} =10V, I _D =20A	---	99	---	nC
Gate-Source Charge	Q _{gs}		---	21	---	
Gate-Drain Charge	Q _{gd}		---	33	---	
Turn-On Delay Time	T _{d(on)}	V _{DS} =50V, V _{GS} =10V, R _G =3Ω, I _D =20A	---	22	---	ns
Rise Time	T _r		---	35	---	
Turn-Off Delay Time	T _{d(off)}		---	52	---	
Fall Time	T _f		---	31	---	
Input Capacitance	C _{iss}	V _{DS} =50V, V _{GS} =0V, f=1MHz	---	5345	---	pF
Output Capacitance	C _{oss}		---	740	---	
Reverse Transfer Capacitance	C _{rss}		---	20	---	

Drain-Source Diode Characteristics

Parameter	Symbol	Conditions	Min	Typ	Max	Unit
Diode Forward Voltage ²	V _{SD}	V _{GS} =0V, I _S =20A, T _J =25°C	---	---	1.2	V
Reverse recovery time	t _{rr}	I _F =20A, diF/dt=125A/μs	---	58	---	ns
Reverse recovery charge	Q _{rr}		---	82	---	nC

Note:

1. The data tested by surface mounted on a 1 inch² FR-4 board with 2OZ copper.
2. The data tested by pulsed, pulse width ≤ 300us, duty cycle ≤ 2%
3. The EAS data shows Max. rating. The test condition is V_{DD}=35V, V_{GS}=10V, L=0.4mH
4. The power dissipation is limited by 150°C junction temperature

Typical Characteristics

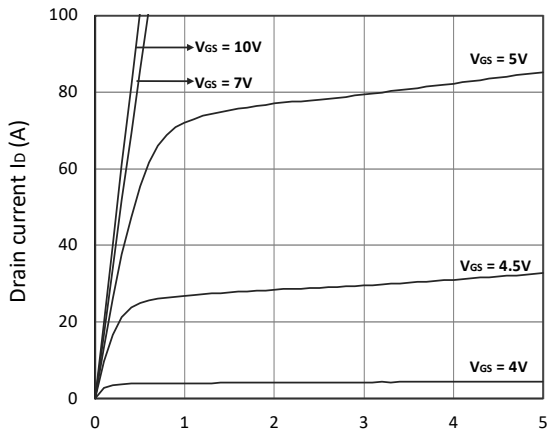

Figure 1. Output Characteristics

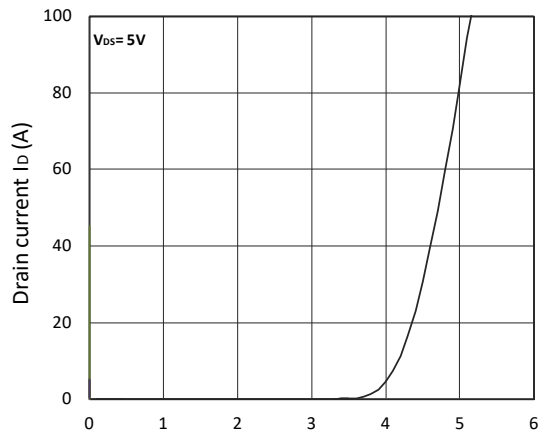

Figure 2. Transfer Characteristics

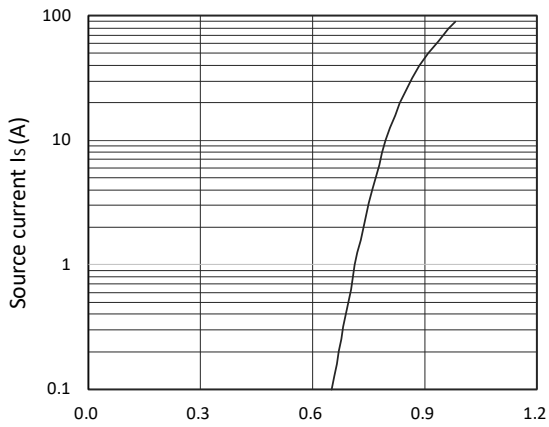

Figure 3. Forward Characteristics of Reverse

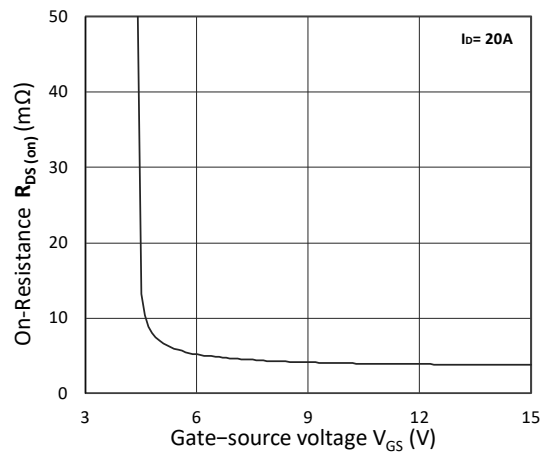

Figure 4. $R_{DS(on)}$ vs. V_{GS}

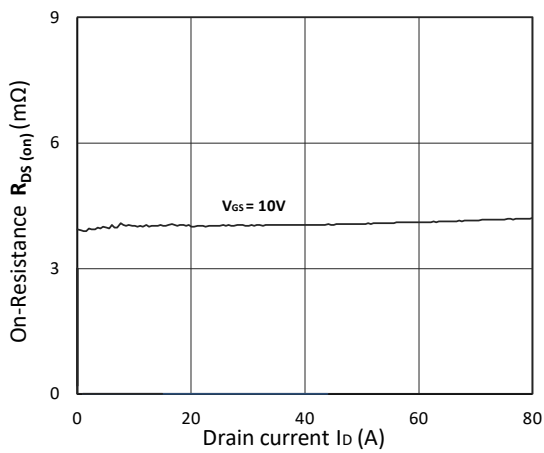

Figure 5. $R_{DS(on)}$ vs. I_D

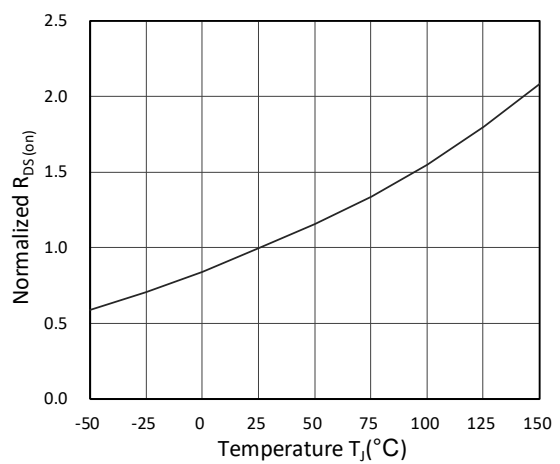

Figure 6. Normalized $R_{DS(on)}$ vs. Temperature

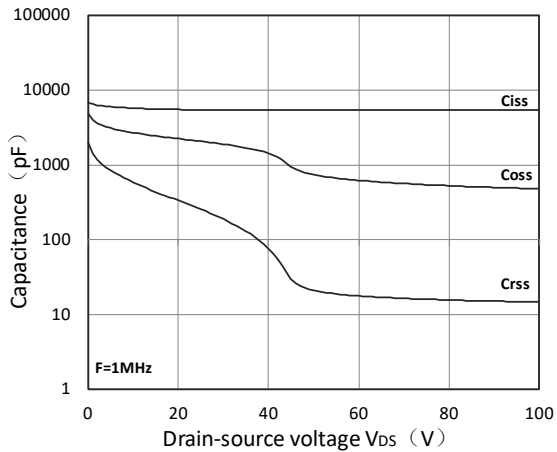

Figure 7. Capacitance Characteristics

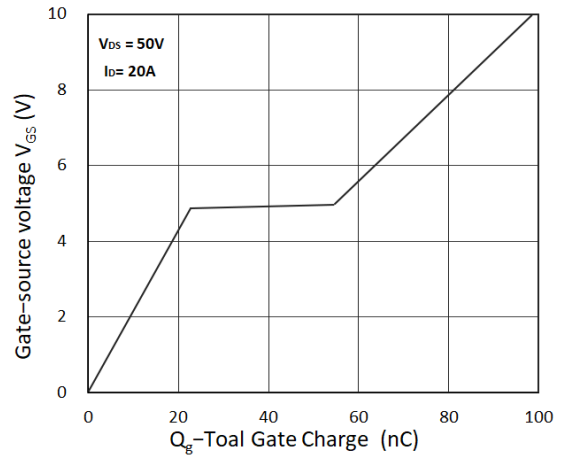

Figure 8. Gate Charge Characteristics

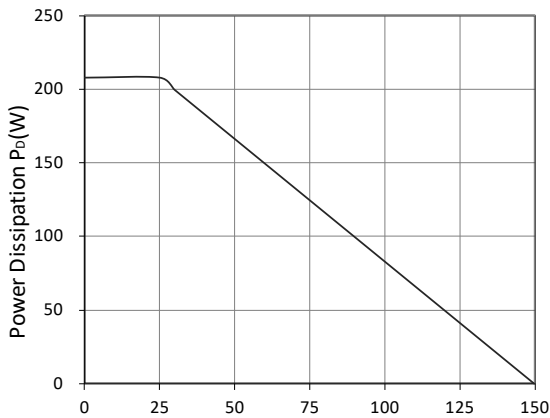

Figure 9. Power Dissipation

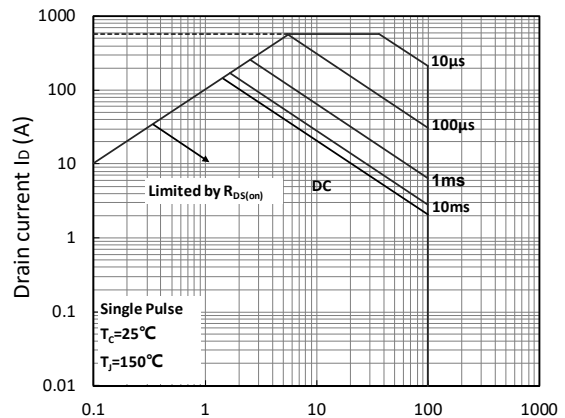

Figure 10. Safe Operating Area

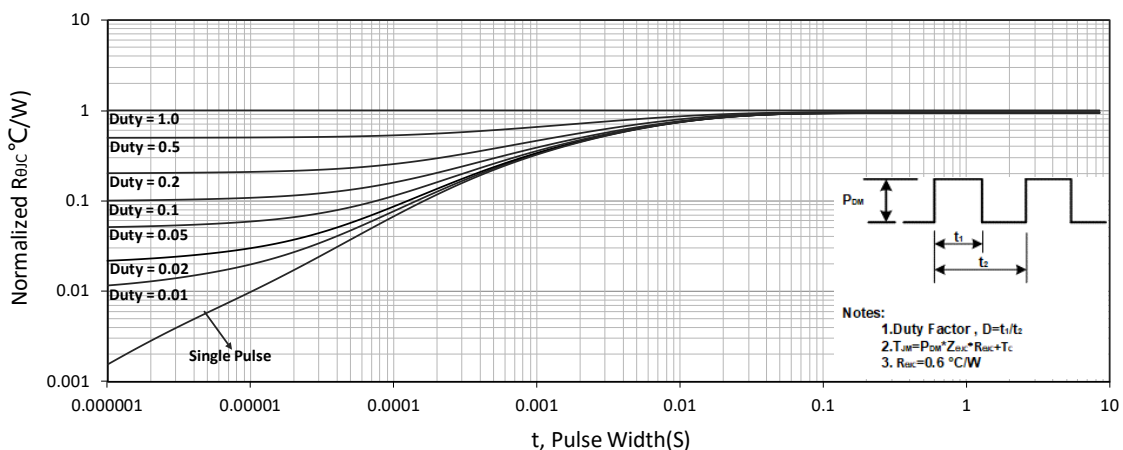
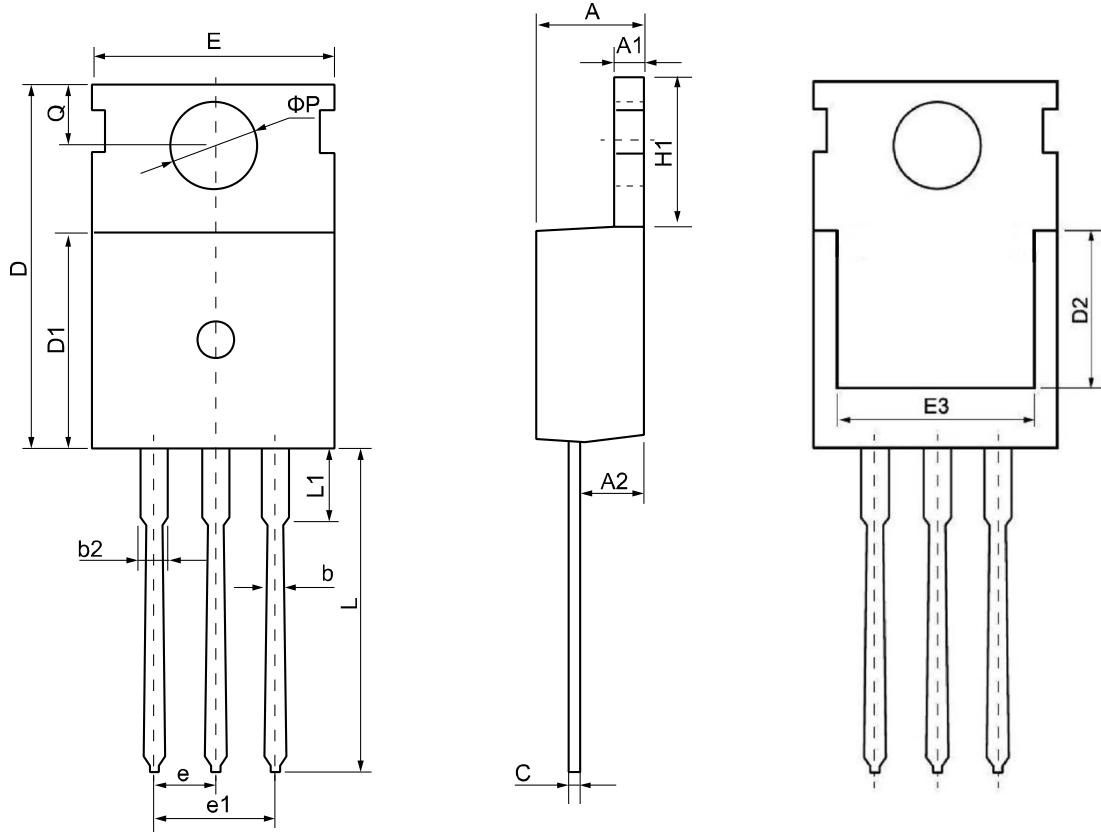

Figure 11. Normalized Maximum Transient Thermal Impedance

TO-220 Package Outline Dimensions



Symbol	Dimensions (unit:mm)			Symbol	Dimensions (unit:mm)		
	Min	Typ	Max		Min	Typ	Max
A	4.30	4.55	4.75	E	9.65	10.00	10.25
A1	1.15	1.30	1.45	E3	7.00	--	--
A2	2.20	2.40	2.60	e	2.54 BSC		
b	0.70	0.80	0.95	e1	5.08 BSC		
b2	1.17	1.27	1.47	H1	6.30	6.50	6.80
c	0.40	0.50	0.65	L	12.70	13.50	14.10
D	15.30	15.60	15.90	L1	--	3.20	3.95
D1	8.90	9.10	9.35	φP	3.40	3.60	3.80
D2	5.50	--	--	Q	2.60	2.80	3.00

Printing Information

ATC =====Brand

XXXXXXX =====Material Code

XXYY =====XX Representative Year
 YY Representative Weeks