

Features

- Advanced high cell density Trench technology
- Super Low Gate Charge
- Excellent CdV/dt effect decline
- 100% EAS Guaranteed
- Green Device Available

Product Summary



| | | |
|---------------------------------|-----|------------|
| V_{DS} | 85 | V |
| I_D | 200 | A |
| $R_{DS(ON)}$ (at $V_{GS}=10V$) | 2.8 | m Ω |

Applications

- High Frequency Point-of-Load, Synchronous Buck Converter
- Networking DC-DC Power System
- Load Switch

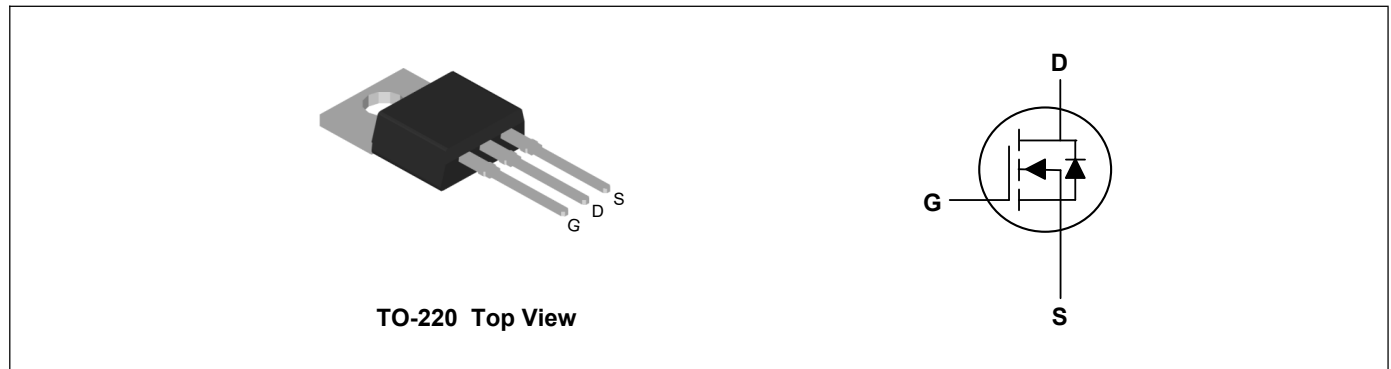

Absolute Maximum Ratings($T_C=25^{\circ}C$, unless otherwise noted)

| Parameter | Symbol | Rating | Units |
|--|-----------|------------|-------------|
| Drain-Source Voltage | V_{DS} | 85 | V |
| Gate-Source Voltage | V_{GS} | ± 20 | V |
| Continuous Drain Current ¹ | I_D | 200 | A |
| Pulsed Drain Current ² | I_{DM} | 640 | A |
| Single Pulse Avalanche Energy ³ | E_{AS} | 900 | mJ |
| Total Power Dissipation ⁴ | P_D | 225 | W |
| Storage Temperature Range | T_{STG} | -55 to 150 | $^{\circ}C$ |
| Operating Junction Temperature Range | T_J | -55 to 150 | $^{\circ}C$ |

Thermal Characteristics

| Parameter | Symbol | Typ | Max | Unit |
|--|-----------------|-----|------|---------------|
| Thermal Resistance Junction-Ambient ¹ | $R_{\theta JA}$ | --- | 62.5 | $^{\circ}C/W$ |
| Thermal Resistance Junction-Case ¹ | $R_{\theta JC}$ | --- | 0.55 | $^{\circ}C/W$ |

Electrical Characteristics (T_J=25°C, unless otherwise noted)

| Parameter | Symbol | Conditions | Min | Typ | Max | Unit |
|-----------------------------------|---------------------|---|-----|------|------|------|
| Drain-Source Breakdown Voltage | BV _{DSS} | V _{GS} =0V, I _D =250uA | 85 | --- | --- | V |
| Static Drain-Source On-Resistance | R _{DS(ON)} | V _{GS} =10V, I _D =30A | --- | 2.4 | 2.8 | mΩ |
| Gate Threshold Voltage | V _{GS(th)} | V _{GS} =V _{DS} , I _D =250uA | 2 | --- | 4 | V |
| Drain-Source Leakage Current | I _{DSS} | V _{DS} =85V, V _{GS} =0V | --- | --- | 1 | uA |
| Gate-Source Leakage Current | I _{GSS} | V _{GS} =±20V, V _{DS} =0V | --- | --- | ±100 | nA |
| Total Gate Charge | Q _g | V _{DS} =40V, V _{GS} =10V, I _D =30A | --- | 110 | --- | nC |
| Gate-Source Charge | Q _{gs} | | --- | 28 | --- | |
| Gate-Drain Charge | Q _{gd} | | --- | 25 | --- | |
| Turn-On Delay Time | T _{d(on)} | V _{DD} =40V, V _{GS} =10V, R _G =4.5Ω, I _D =30A | --- | 23 | --- | ns |
| Rise Time | T _r | | --- | 68 | --- | |
| Turn-Off Delay Time | T _{d(off)} | | --- | 71 | --- | |
| Fall Time | T _f | | --- | 75 | --- | |
| Input Capacitance | C _{iss} | V _{DS} =40V, V _{GS} =0V, f=1MHz | --- | 6900 | --- | pF |
| Output Capacitance | C _{oss} | | --- | 750 | --- | |
| Reverse Transfer Capacitance | C _{rss} | | --- | 75 | --- | |

Drain-Source Diode Characteristics

| Parameter | Symbol | Conditions | Min | Typ | Max | Unit |
|------------------------------------|-----------------|--|-----|-----|-----|------|
| Diode Forward Voltage ² | V _{SD} | V _{GS} =0V, I _F =30A, T _J =25°C | --- | --- | 1.3 | V |
| Reverse Recovery Time | t _{rr} | I _F =30A | --- | 62 | --- | nS |
| Reverse Recovery Charge | Q _{rr} | di/dt=100A/μs, T _J =25°C | --- | 83 | --- | nC |

Note:

- 1.The data tested by surface mounted on a 1 inch² FR-4 board with 2OZ copper.
- 2.The data tested by pulsed, pulse width ≤ 300us, duty cycle ≤ 2%
- 3.The EAS data shows Max. rating. The test condition is V_{DD}=50V, V_{GS}=10V, L=0.1mH
- 4.The power dissipation is limited by 150°C junction temperature

Typical Characteristics

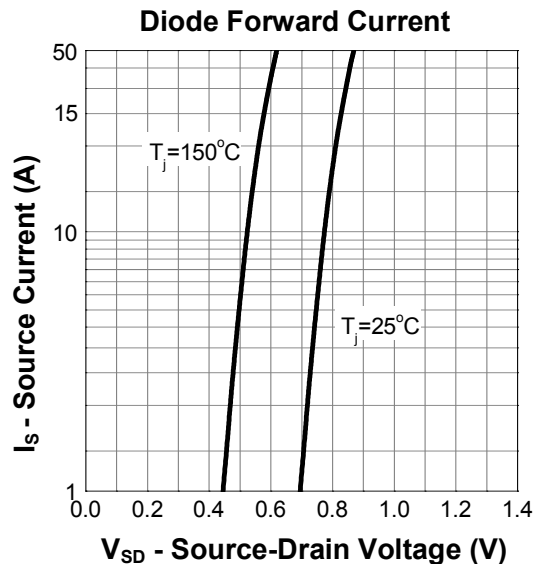
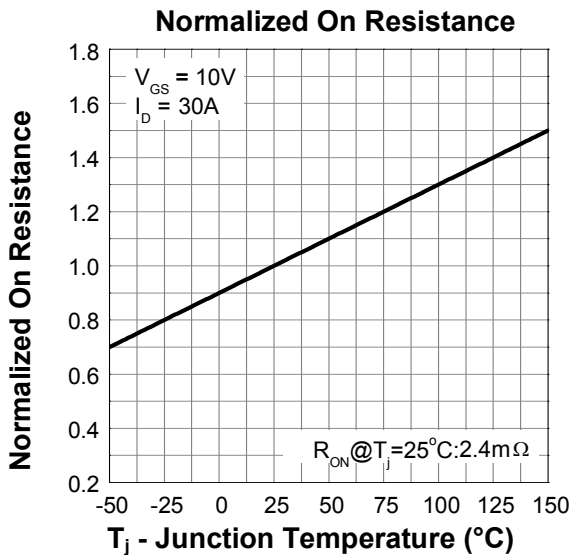
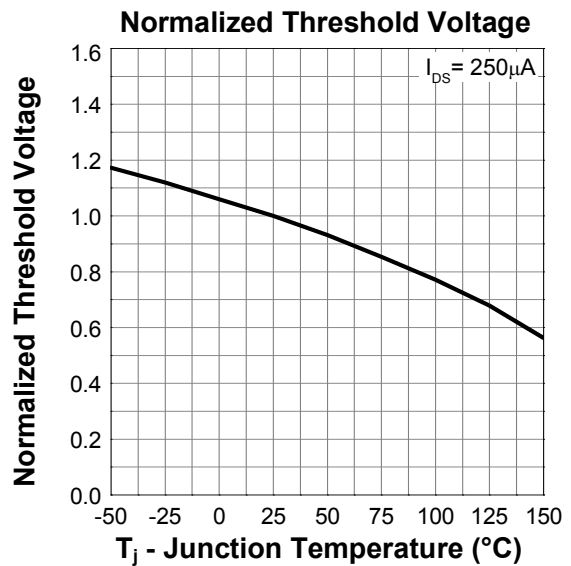
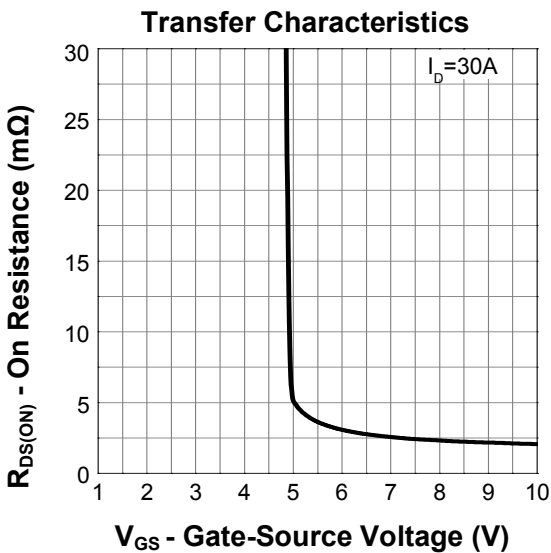
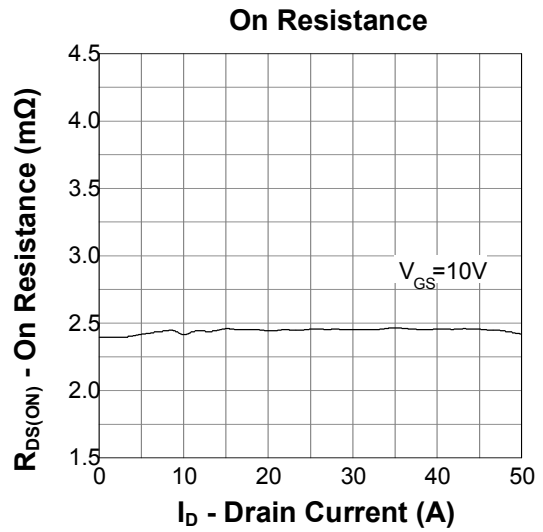
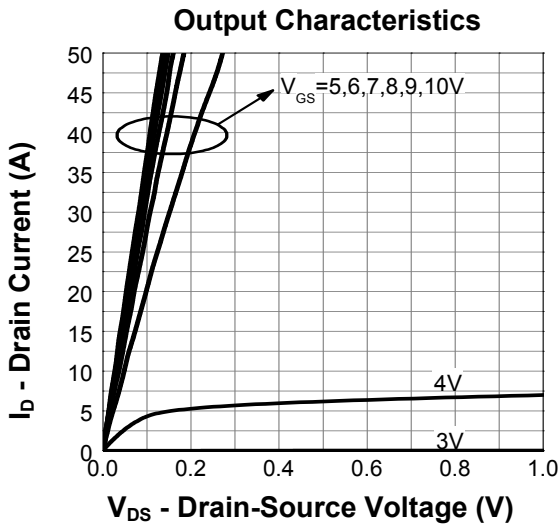

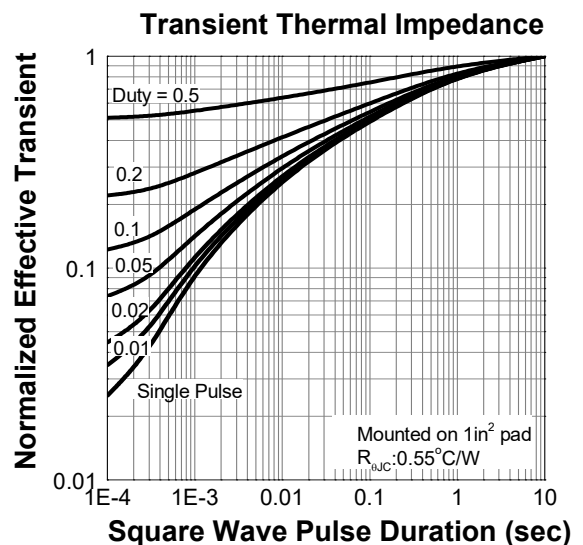
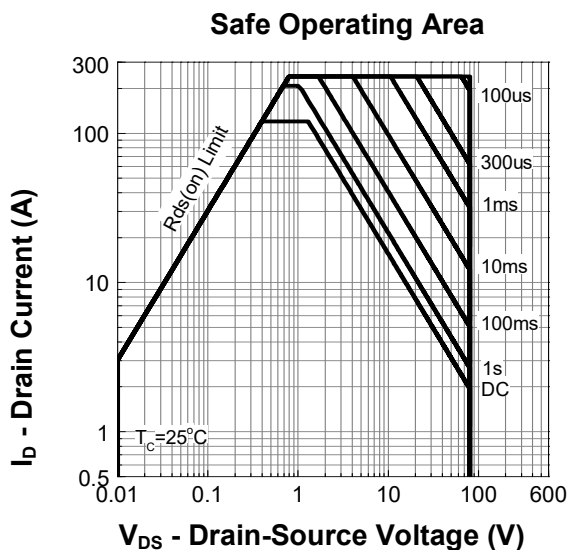
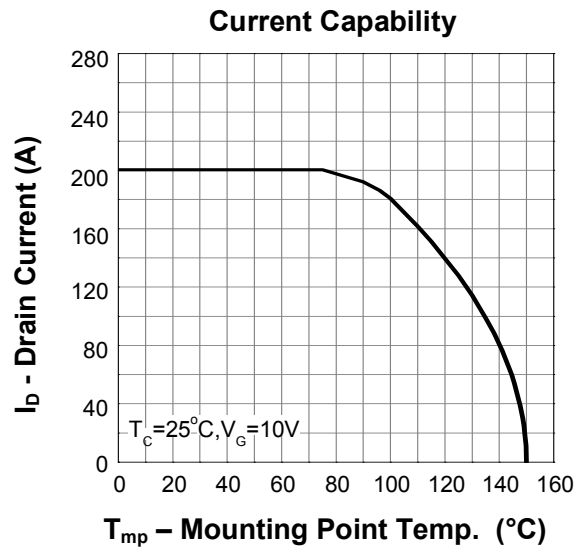
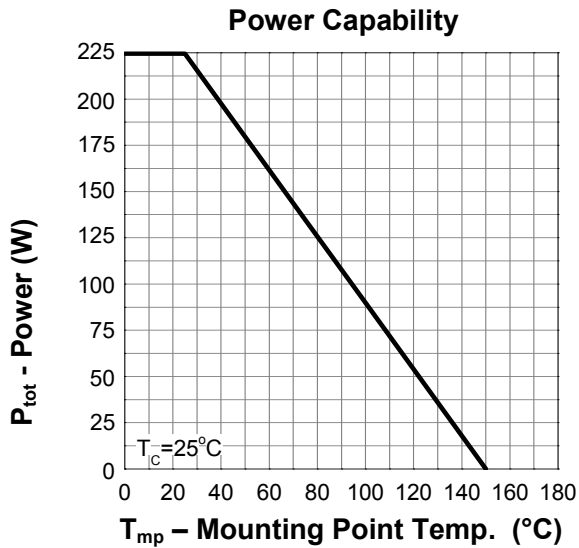
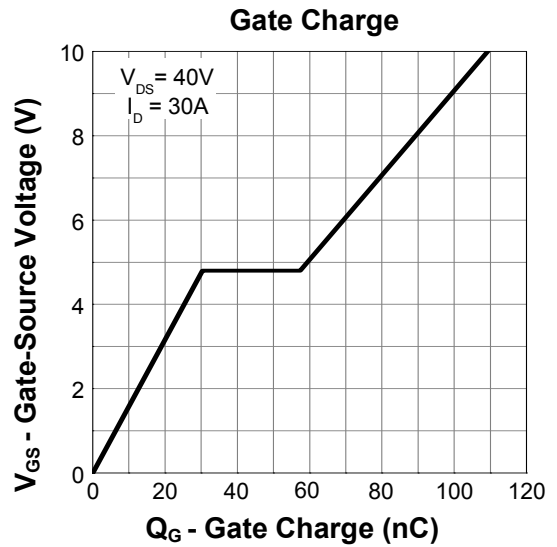
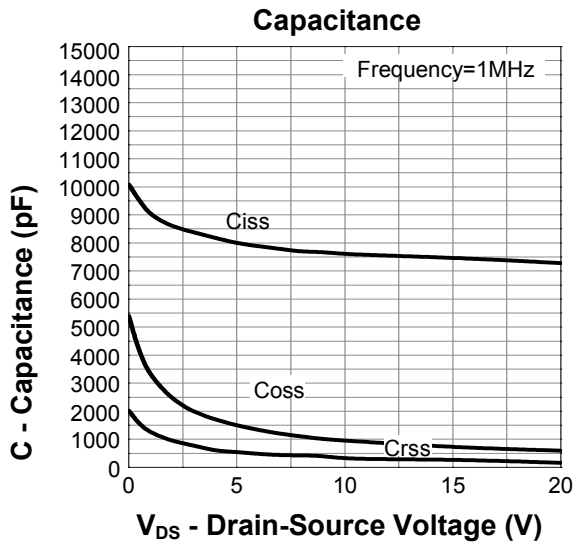

TO-220 Package Outline Dimensions

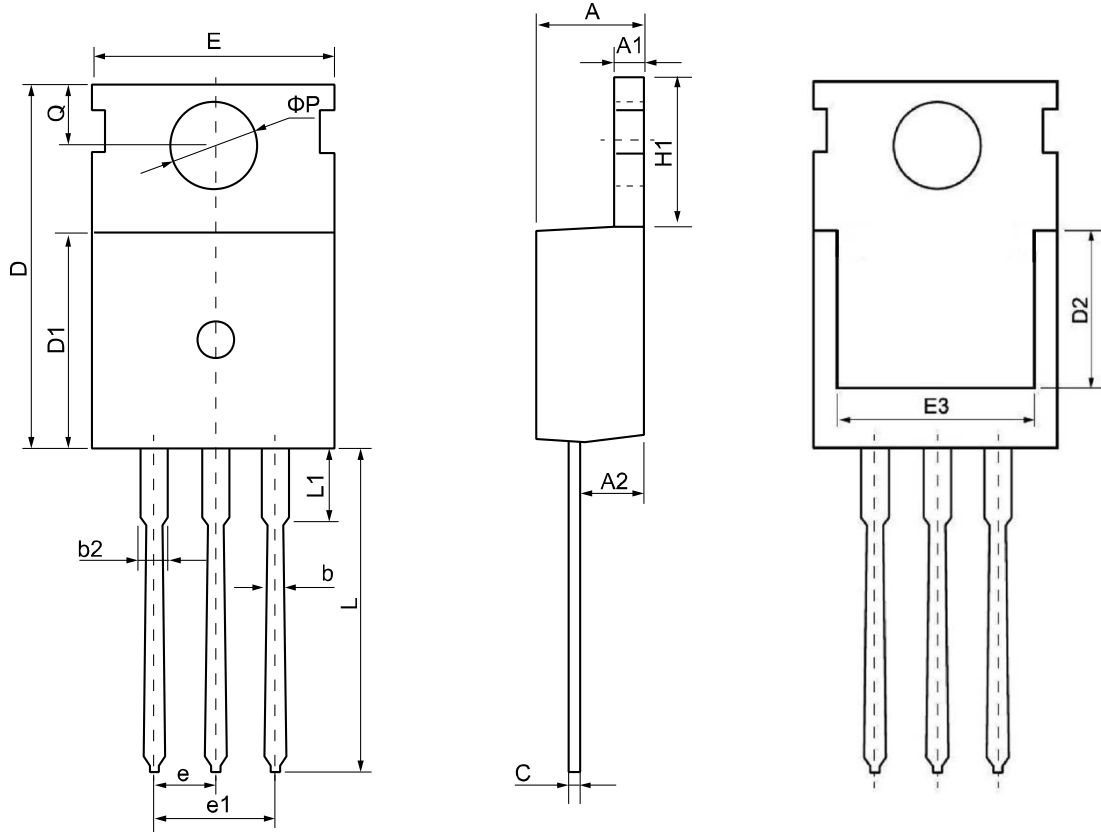

| Symbol | Dimensions (unit:mm) | | | Symbol | Dimensions (unit:mm) | | |
|-----------|----------------------|-------|-------|----------------------------|----------------------|-------|-------|
| | Min | Typ | Max | | Min | Typ | Max |
| A | 4.30 | 4.55 | 4.75 | E | 9.65 | 10.00 | 10.25 |
| A1 | 1.15 | 1.30 | 1.45 | E3 | 7.00 | -- | -- |
| A2 | 2.20 | 2.40 | 2.60 | e | 2.54 BSC | | |
| b | 0.70 | 0.80 | 0.95 | e1 | 5.08 BSC | | |
| b2 | 1.17 | 1.27 | 1.47 | H1 | 6.30 | 6.50 | 6.80 |
| c | 0.40 | 0.50 | 0.65 | L | 12.70 | 13.50 | 14.10 |
| D | 15.30 | 15.60 | 15.90 | L1 | -- | 3.20 | 3.95 |
| D1 | 8.90 | 9.10 | 9.35 | ϕP | 3.40 | 3.60 | 3.80 |
| D2 | 5.50 | -- | -- | Q | 2.60 | 2.80 | 3.00 |