

**Features**

- Advanced high cell density Trench technology
- Super Low Gate Charge
- Excellent CdV/dt effect decline
- 100% EAS Guaranteed
- Green Device Available

**Product Summary**



|                                 |      |            |
|---------------------------------|------|------------|
| $V_{DS}$                        | 40   | V          |
| $I_D$                           | 165  | A          |
| $R_{DS(ON)}$ (at $V_{GS}=10V$ ) | 0.95 | m $\Omega$ |
| $R_{DS(ON)}$ (at $V_{GS}=6V$ )  | 2.85 | m $\Omega$ |

**Applications**

- High Frequency Point-of-Load, Synchronous Buck Converter
- Networking DC-DC Power System
- UPS Inverter

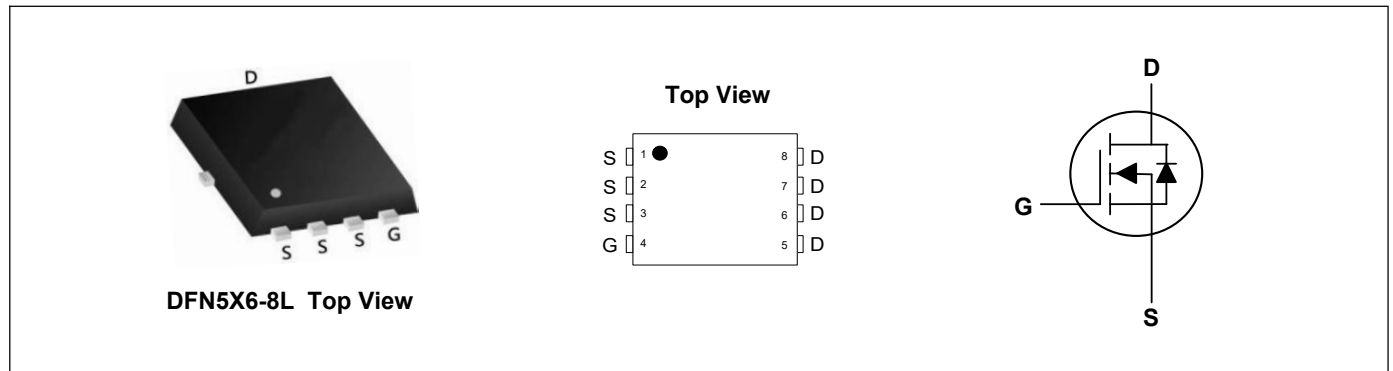

**Absolute Maximum Ratings( $T_C=25^{\circ}C$ , unless otherwise noted)**

| Parameter                             | Symbol    | Rating     | Units       |
|---------------------------------------|-----------|------------|-------------|
| Drain-Source Voltage                  | $V_{DS}$  | 40         | V           |
| Gate-Source Voltage                   | $V_{GS}$  | $\pm 20$   | V           |
| Continuous Drain Current <sup>1</sup> | $I_D$     | 165        | A           |
| Pulsed Drain Current <sup>2</sup>     | $I_{DM}$  | 652        | A           |
| Total Power Dissipation <sup>3</sup>  | $P_D$     | 42         | mW          |
| Storage Temperature Range             | $T_{STG}$ | -55 to 150 | $^{\circ}C$ |
| Operating Junction Temperature Range  | $T_J$     | -55 to 150 | $^{\circ}C$ |

**Thermal Characteristics**

| Parameter                           | Symbol          | Typ | Max  | Unit          |
|-------------------------------------|-----------------|-----|------|---------------|
| Thermal Resistance Junction-Ambient | $R_{\theta JA}$ | --- | 62.5 | $^{\circ}C/W$ |

**Electrical Characteristics (T<sub>J</sub>=25°C, unless otherwise noted)**

| Parameter                         | Symbol              | Conditions  | Min | Typ  | Max  | Unit |
|-----------------------------------|---------------------|---|-----|------|------|------|
| Drain-Source Breakdown Voltage    | BV <sub>DSS</sub>   | V <sub>GS</sub> =0V, I <sub>D</sub> =250uA  | 40  | ---  | ---  | V    |
| Static Drain-Source On-Resistance | R <sub>DS(ON)</sub> | V <sub>GS</sub> =10V, I <sub>D</sub> =30A   | --- | 0.8  | 0.95 | mΩ   |
|                                   |                     | V <sub>GS</sub> =6V, I <sub>D</sub> =20A  | --- | 2.4  | 2.85 | mΩ   |
| Gate Threshold Voltage            | V <sub>GS(th)</sub> | V <sub>GS</sub> =V <sub>DS</sub> , I <sub>D</sub> =250uA                              | 2.0 | ---  | 4.0  | V    |
| Drain-Source Leakage Current      | I <sub>DSS</sub>    | V <sub>DS</sub> =32V, V <sub>GS</sub> =0V   | --- | ---  | 1    | uA   |
| Gate-Source Leakage Current       | I <sub>GSS</sub>    | V <sub>GS</sub> =±20V, V <sub>DS</sub> =0V  | --- | ---  | ±100 | nA   |
| Forward Transconductance          | g <sub>fs</sub>     | V <sub>DS</sub> =5V, I <sub>D</sub> =20A  | --- | ---  | ---  | S    |
| Total Gate Charge                 | Q <sub>g</sub>      | V <sub>DS</sub> =20V, V <sub>GS</sub> =10V, I <sub>D</sub> =30A                       | --- | 80   | ---  | nC   |
| Gate-Source Charge                | Q <sub>gs</sub>     |   | --- | 26   | ---  |      |
| Gate-Drain Charge                 | Q <sub>gd</sub>     |   | --- | 20   | ---  |      |
| Turn-On Delay Time                | T <sub>d(on)</sub>  | V <sub>DS</sub> =20V, V <sub>GS</sub> =10V, R <sub>G</sub> =3.9Ω, I <sub>D</sub> =30A | --- | 18   | ---  | ns   |
| Rise Time                         | T <sub>r</sub>      |   | --- | 78   | ---  |      |
| Turn-Off Delay Time               | T <sub>d(off)</sub> |   | --- | 50   | ---  |      |
| Fall Time                         | T <sub>f</sub>      |   | --- | 45   | ---  |      |
| Input Capacitance                 | C <sub>iss</sub>    | V <sub>DS</sub> =20V, V <sub>GS</sub> =0V, f=1MHz                                     | --- | 4850 | ---  | pF   |
| Output Capacitance                | C <sub>oss</sub>    |   | --- | 2000 | ---  |      |
| Reverse Transfer Capacitance      | C <sub>rss</sub>    |   | --- | 165  | ---  |      |

**Drain-Source Diode Characteristics**

| Parameter                          | Symbol          | Conditions   | Min | Typ | Max | Unit |
|------------------------------------|-----------------|--|-----|-----|-----|------|
| Diode Forward Voltage <sup>2</sup> | V <sub>SD</sub> | V <sub>GS</sub> =0V, I <sub>F</sub> =30A, T <sub>J</sub> =25°C | --- | --- | 1.3 | V    |
| Reverse Recovery Time              | t <sub>rr</sub> | I <sub>F</sub> =30A  | --- | 62  | --- | nS   |
| Reverse Recovery Charge            | Q <sub>rr</sub> | di/dt=100A/μs, T <sub>J</sub> =25°C                            | --- | 65  | --- | nC   |

**Note:**

- 1.The data tested by surface mounted on a 1 inch<sup>2</sup> FR-4 board with 2OZ copper.
- 2.The data tested by pulsed, pulse width ≤ 300us, duty cycle ≤ 2%
- 3.The EAS data shows Max. rating. The test condition is V<sub>DD</sub>=20V, V<sub>GS</sub>=10V, L=0.5mH
- 4.The power dissipation is limited by 150°C junction temperature

**Typical Characteristics**

**Output Characteristics**

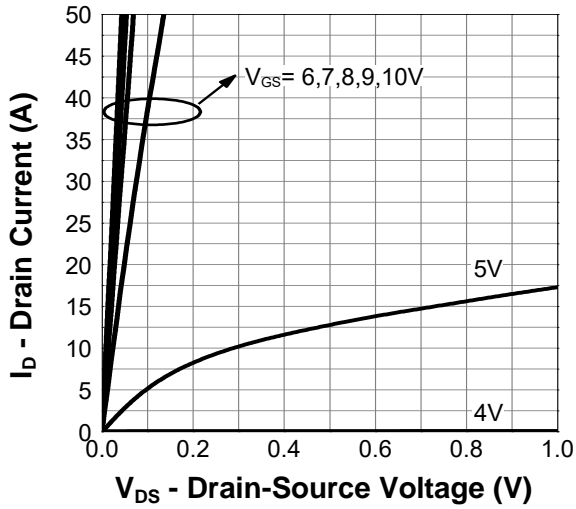

**On Resistance**

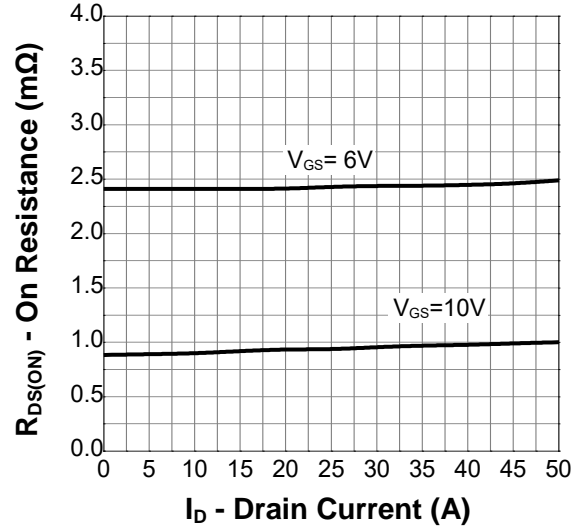

**Transfer Characteristics**

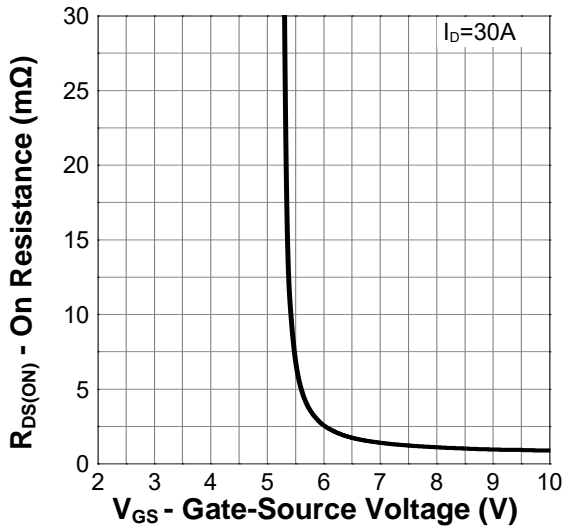

**Normalized On Resistance**

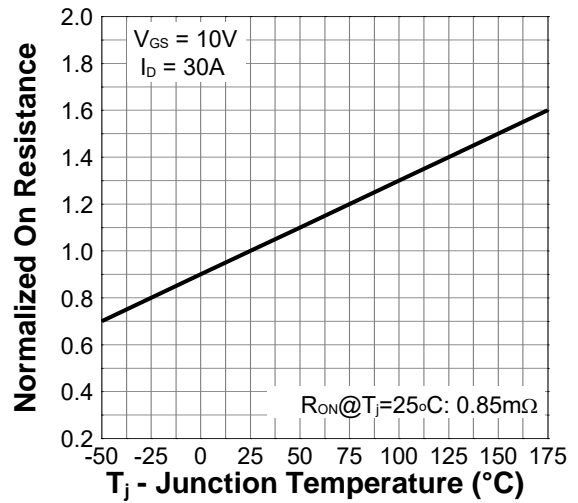

**Capacitance**

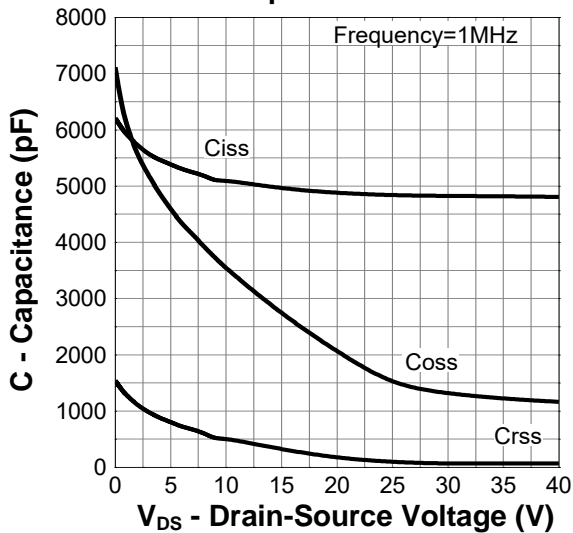

**Gate Charge**

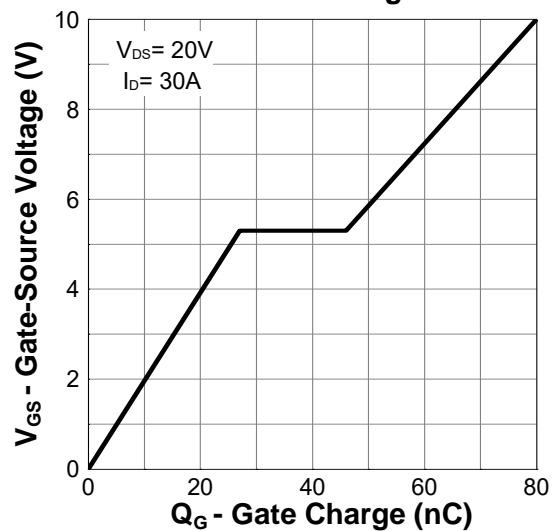

**Power Capability**

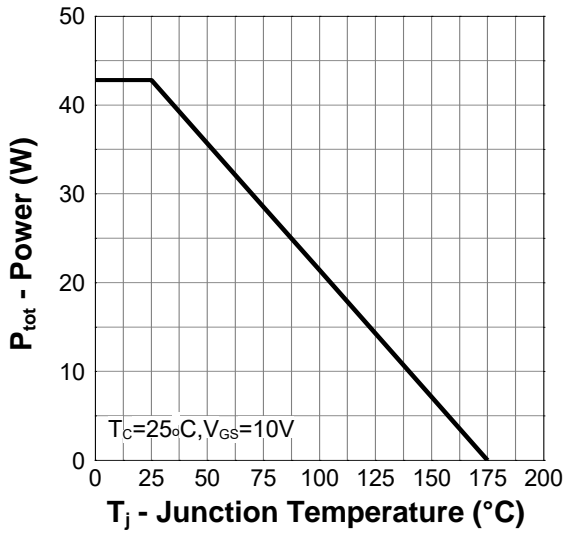

**Current Capability**

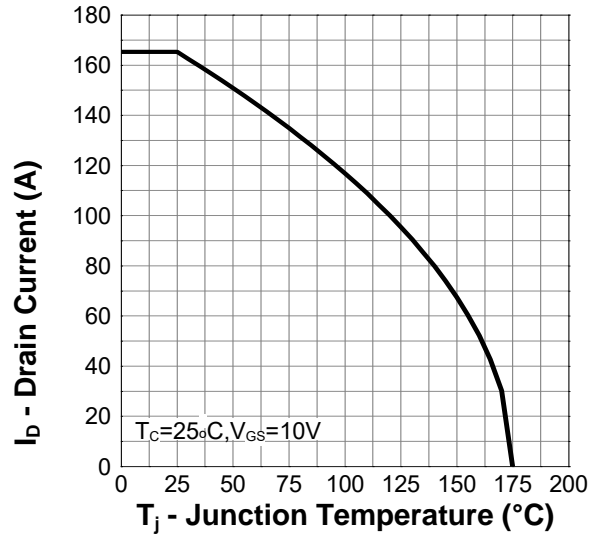

**Safe Operation Area**

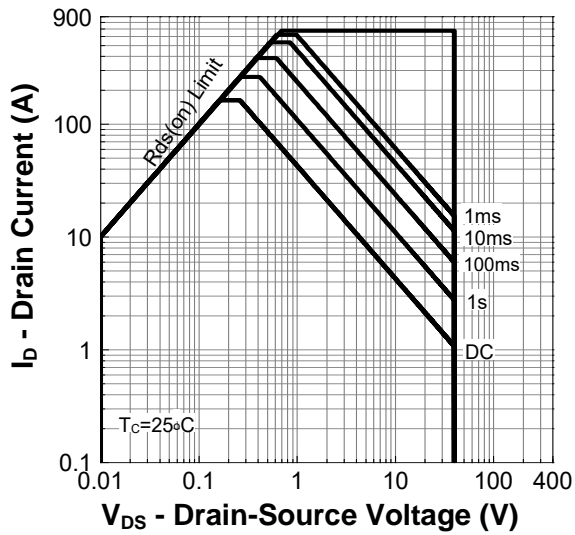

**Transient Thermal Impedance**

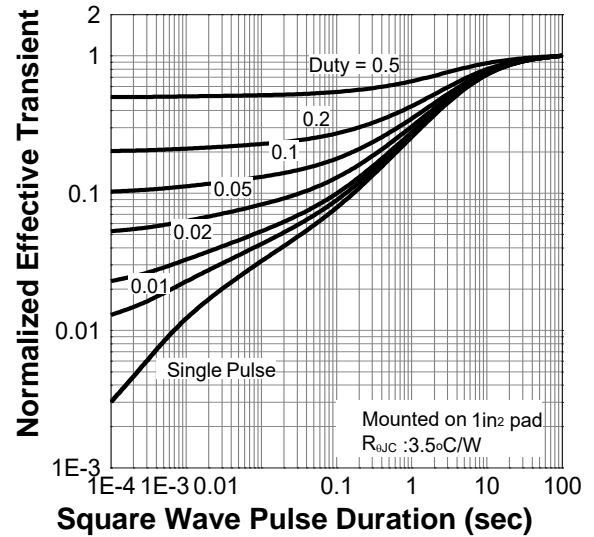

**DFN5X6-8L Package Outline Dimensions**

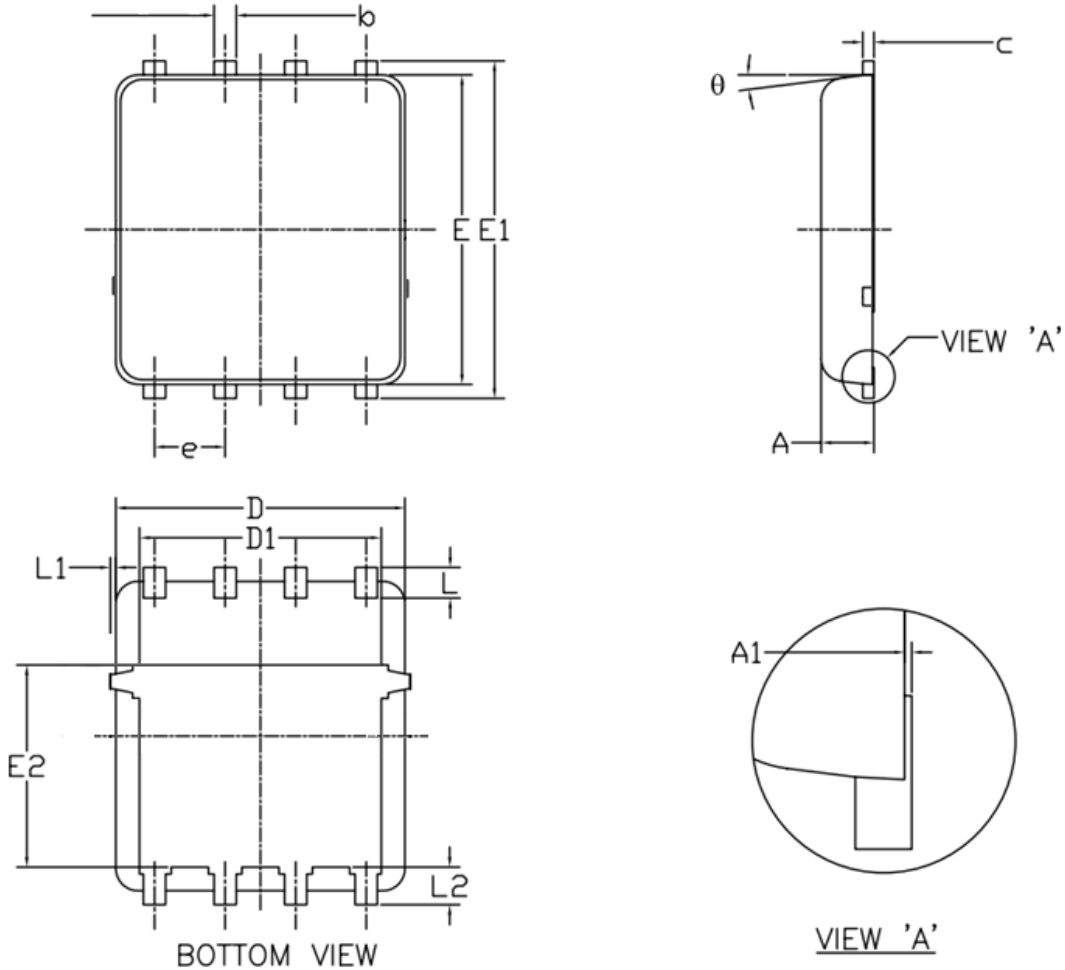

| Symbol    | Dimensions (unit:mm) |      |      | Symbol                     | Dimensions (unit:mm) |      |      |
|-----------|----------------------|------|------|----------------------------|----------------------|------|------|
|           | Min                  | Typ  | Max  |                            | Min                  | Typ  | Max  |
| <b>A</b>  | 0.90                 | 1.00 | 1.20 | <b>E1</b>                  | 5.90                 | 6.10 | 6.35 |
| <b>A1</b> | 0.00                 | --   | 0.05 | <b>E2</b>                  | 3.38                 | 3.58 | 3.92 |
| <b>b</b>  | 0.30                 | 0.40 | 0.51 | <b>e</b>                   | 1.27 BSC             |      |      |
| <b>c</b>  | 0.20                 | 0.25 | 0.33 | <b>L</b>                   | 0.51                 | 0.61 | 0.71 |
| <b>D</b>  | 4.80                 | 4.90 | 5.40 | <b>L1</b>                  | --                   | --   | 0.15 |
| <b>D1</b> | 3.61                 | 4.00 | 4.25 | <b>L2</b>                  | 0.41                 | 0.51 | 0.61 |
| <b>E</b>  | 5.65                 | 5.80 | 6.06 | <b><math>\theta</math></b> | 0°                   | --   | 12°  |