

Features

- Advanced high cell density Trench technology
- Super Low Gate Charge
- Excellent CdV/dt effect decline
- 100% EAS Guaranteed
- Green Device Available

Product Summary



V_{DS}	-60	V
I_D	-10	A
$R_{DS(ON)}$ (at $V_{GS}=-10V$)	130	m Ω
$R_{DS(ON)}$ (at $V_{GS}=-4.5V$)	180	m Ω

Applications

- High Frequency Point-of-Load, Synchronous Buck Converter for MB/NB/UMPC/VGA
- Networking DC-DC Power System
- Load Switch



Absolute Maximum Ratings($T_C=25^{\circ}C$, unless otherwise noted)

Parameter	Symbol	Rating	Units
Drain-Source Voltage	V_{DS}	-60	V
Gate-Source Voltage	V_{GS}	± 20	V
Continuous Drain Current ¹	$I_D@T_C=25^{\circ}C$	-10	A
Continuous Drain Current ¹	$I_D@T_C=100^{\circ}C$	-8	A
Pulsed Drain Current ²	I_{DM}	-6	A
Single Pulse Avalanche Energy	EAS	26	mJ
Total Power Dissipation	P_D	25	W
Storage Temperature Range	T_{STG}	-55 to 150	$^{\circ}C$
Operating Junction Temperature Range	T_J	-55 to 150	$^{\circ}C$

Thermal Characteristics

Parameter	Symbol	Typ	Max	Unit
Thermal Resistance Junction-Case ¹	$R_{\theta JC}$	---	1.2	$^{\circ}C/W$

Electrical Characteristics ($T_J=25^\circ\text{C}$, unless otherwise noted)

Parameter	Symbol	Conditions	Min	Typ	Max	Unit
Drain-Source Breakdown Voltage	BV_{DSS}	$V_{GS}=0V, I_D=-250\mu A$	-60	---	---	V
Static Drain-Source On-Resistance	$R_{DS(ON)}$	$V_{GS}=-10V, I_D=-1.5A$	---	110	130	$m\Omega$
		$V_{GS}=-4.5V, I_D=-1A$	---	150	180	$m\Omega$
Gate Threshold Voltage	$V_{GS(th)}$	$V_{GS}=V_{DS}, I_D=-250\mu A$	-1	---	-3	V
Drain-Source Leakage Current	I_{DSS}	$V_{DS}=-48V, V_{GS}=0V$	---	---	-1	μA
Gate-Source Leakage Current	I_{GSS}	$V_{GS}=\pm 20V, V_{DS}=0V$	---	---	± 100	nA
Total Gate Charge	Q_g	$V_{DS}=-20V, V_{GS}=-10V, I_D=-1.5A$	---	9.5	---	nC
Gate-Source Charge	Q_{gs}		---	1.52	---	
Gate-Drain Charge	Q_{gd}		---	1.76	---	
Turn-On Delay Time	$T_{d(on)}$	$V_{DS}=-15V, V_{GS}=-10V, R_G=3.3\Omega, I_D=-1A$	---	17.4	---	ns
Rise Time	T_r		---	5.4	---	
Turn-Off Delay Time	$T_{d(off)}$		---	37.2	---	
Fall Time	T_f		---	2.4	---	
Input Capacitance	C_{iss}	$V_{DS}=-15V, V_{GS}=0V, f=1MHz$	---	580	---	pF
Output Capacitance	C_{oss}		---	52	---	
Reverse Transfer Capacitance	C_{rss}		---	35	---	

Drain-Source Diode Characteristics

Parameter	Symbol	Conditions	Min	Typ	Max	Unit
Diode Forward Voltage ²	V_{SD}	$V_{GS}=0V, I_S=-1A, T_J=25^\circ\text{C}$	---	---	-1.4	V
Reverse Recovery Time	t_{rr}	$I_F=-20A, di/dt=100A/\mu s, T_J=25^\circ\text{C}$	---	21	---	nS
Reverse Recovery Charge	Q_{rr}		---	15	---	nC

Note:

- 1.The data tested by surface mounted on a 1 inch² FR-4 board with 2OZ copper.
- 2.The data tested by pulsed , pulse width $\leq 300\mu s$, duty cycle $\leq 2\%$

Typical Characteristics

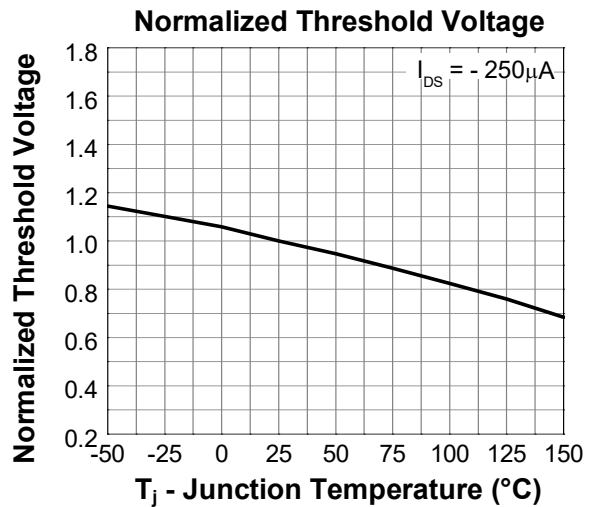
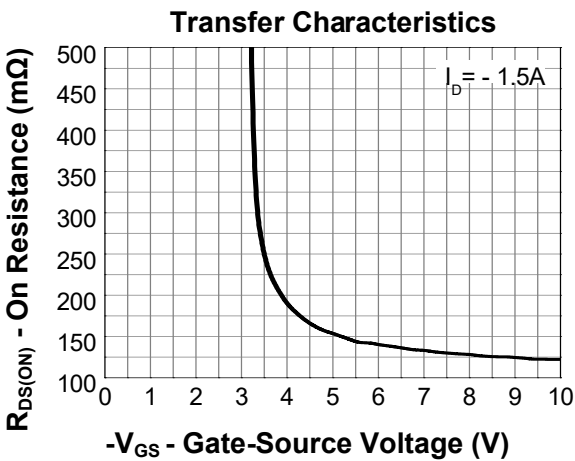
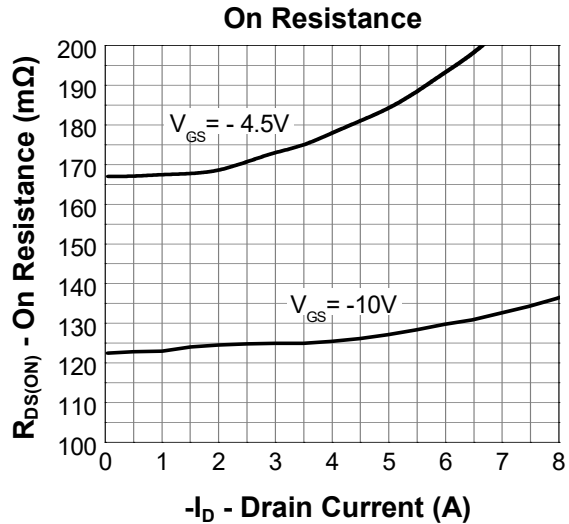
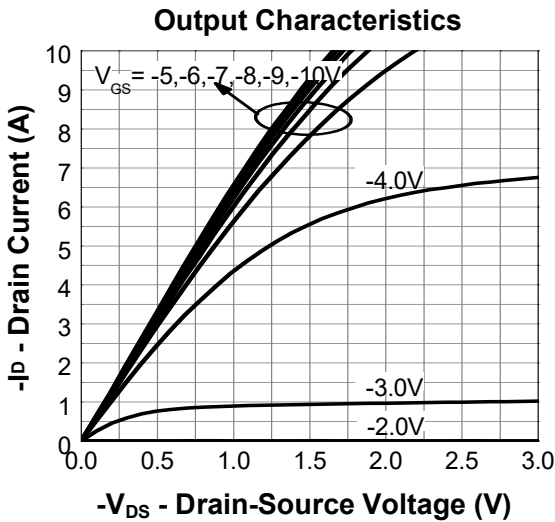
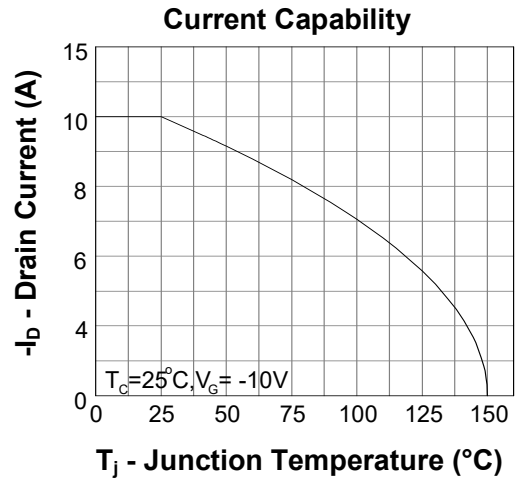
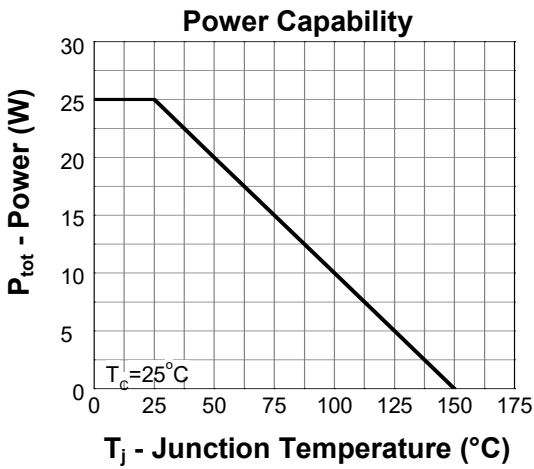

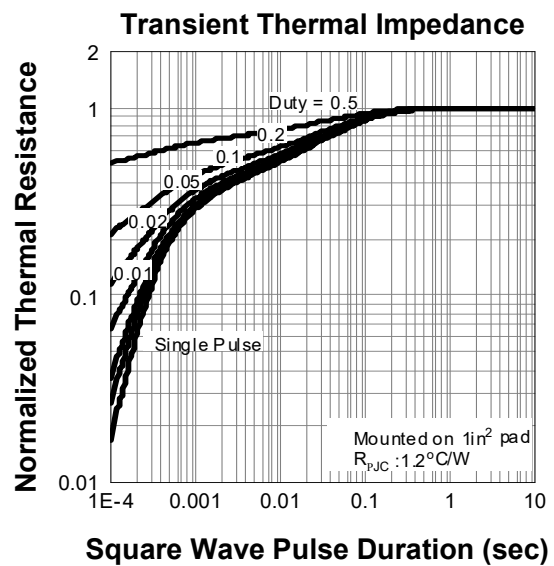
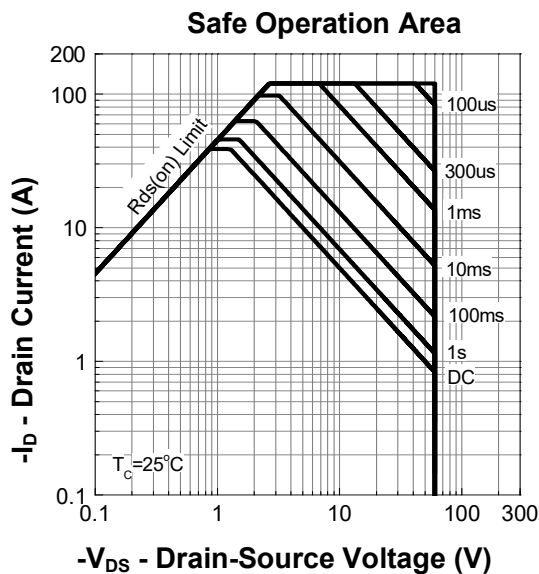
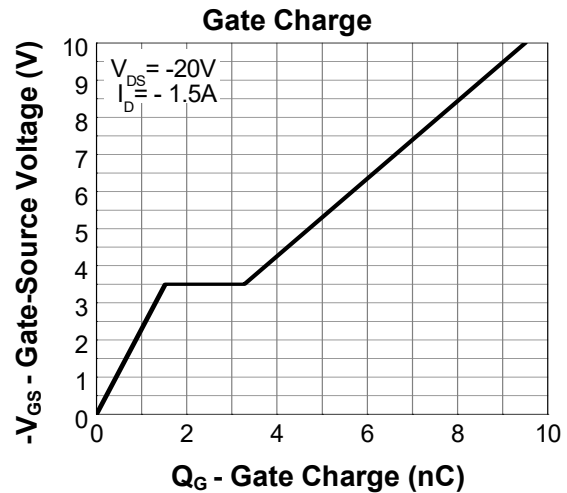
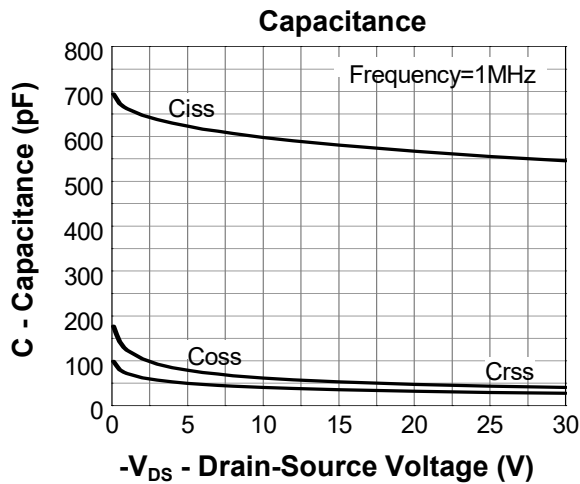
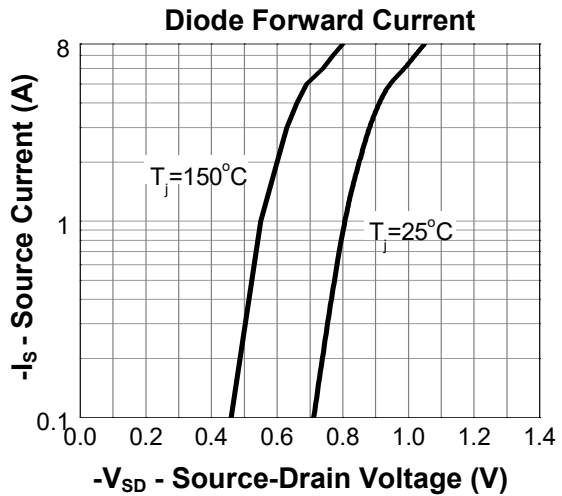
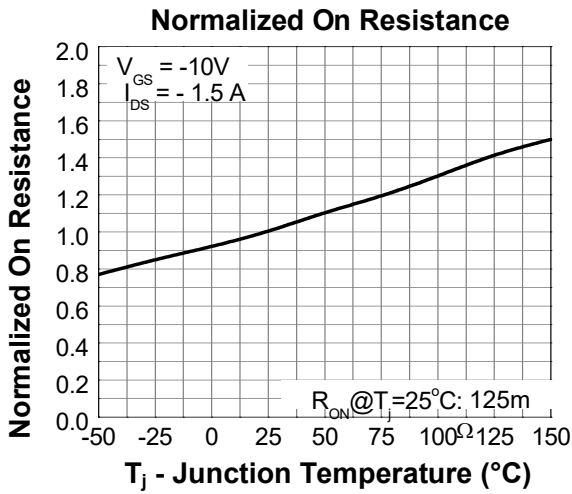

TO-252 Package Outline Dimensions

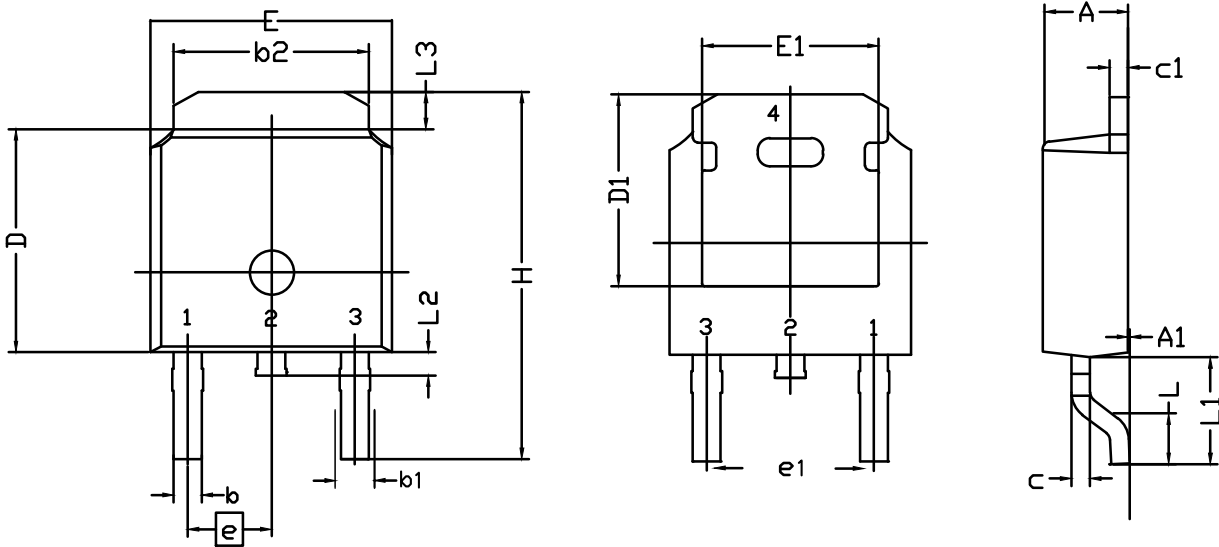

Symbol	Dimensions (unit:mm)			Symbol	Dimensions (unit:mm)		
	Min	Typ	Max		Min	Typ	Max
A	2.20	2.30	2.38	E	6.40	6.60	6.731
A₁	0.00	0.10	0.20	E₁	4.40	--	--
b	0.64	0.76	0.89	e	2.286 BSC		
b₁	0.77	0.85	1.14	e₁	4.572 BSC		
b₂	5.00	5.33	5.46	H	9.40	10.00	10.40
c	0.458	0.508	0.610	L	1.40	1.52	1.77
C₁	0.458	0.508	0.620	L₁	--	2.743	--
D	5.98	6.10	6.223	L₂	0.60	0.80	1.01
D₁	5.20	5.25	5.38	L₃	0.90	1.06	1.25