

## Features

- Advanced high cell density Trench technology
- Super Low Gate Charge
- Excellent CdV/dt effect decline
- 100% EAS Guaranteed
- Green Device Available

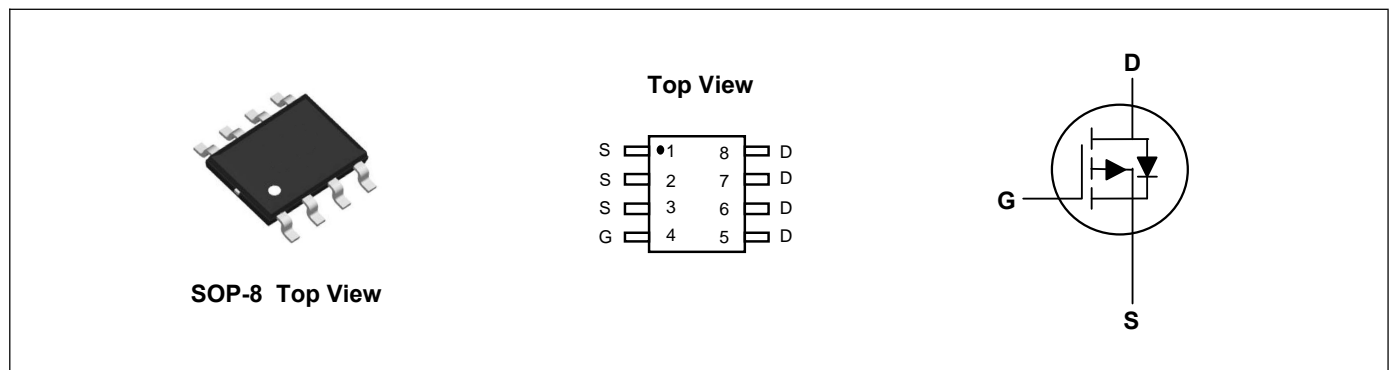
## Applications

- High Frequency Point-of-Load, Synchronous Buck Converter for MB/NB/UMPC/VGA
- Networking DC-DC Power System
- Load Switch

## Product Summary



$V_{DS}$	-60	V
$I_D$	-9	A
$R_{DS(ON)}$ (at $V_{GS}=-10V$ )	38	m $\Omega$
$R_{DS(ON)}$ (at $V_{GS}=-4.5V$ )	50	m $\Omega$



## Absolute Maximum Ratings ( $T_C=25^\circ\text{C}$ , unless otherwise noted)

Parameter	Symbol	Rating	Units
Drain-Source Voltage	$V_{DS}$	-60	V
Gate-Source Voltage	$V_{GS}$	$\pm 20$	V
Continuous Drain Current <sup>1</sup>	$I_D@T_C=25^\circ\text{C}$	-9	A
Continuous Drain Current <sup>1</sup>	$I_D@T_C=100^\circ\text{C}$	-6.4	A
Pulsed Drain Current <sup>2</sup>	$I_{DM}$	-36	A
Single Pulse Avalanche Energy <sup>3</sup>	EAS	156	mJ
Total Power Dissipation <sup>4</sup>	$P_D@T_C=25^\circ\text{C}$	3.0	W
Storage Temperature Range	$T_{STG}$	-55 to 150	$^\circ\text{C}$
Operating Junction Temperature Range	$T_J$	-55 to 150	$^\circ\text{C}$

## Thermal Characteristics

Parameter	Symbol	Typ	Max	Unit
Thermal Resistance Junction-Ambient <sup>1</sup>	$R_{\theta JA}$	---	42	$^\circ\text{C/W}$

**Electrical Characteristics (T<sub>J</sub>=25°C, unless otherwise noted)**

Parameter	Symbol	Conditions	Min	Typ	Max	Unit
Drain-Source Breakdown Voltage	BV <sub>DSS</sub>	V <sub>GS</sub> =0V, I <sub>D</sub> =-250uA	-60	---	---	V
BV <sub>DSS</sub> Temperature Coefficient	ΔBV <sub>DSS</sub> /ΔT <sub>J</sub>	Reference to 25°C, I <sub>D</sub> =-1mA	---	-0.035	---	V/°C
Static Drain-Source On-Resistance	R <sub>DS(ON)</sub>	V <sub>GS</sub> =-10V, I <sub>D</sub> =-9A	---	30	38	mΩ
		V <sub>GS</sub> =-4.5V, I <sub>D</sub> =-9A	---	38	50	mΩ
Gate Threshold Voltage	V <sub>GS(th)</sub>	V <sub>GS</sub> =V <sub>DS</sub> , I <sub>D</sub> =-250uA	-1.0	-1.7	-2.5	V
V <sub>GS(th)</sub> Temperature Coefficient	ΔV <sub>GS(th)</sub>		---	4.25	---	mV/°C
Drain-Source Leakage Current	I <sub>DSS</sub>	V <sub>DS</sub> =-48V, V <sub>GS</sub> =0V, T <sub>J</sub> =25°C	---	---	1	uA
		V <sub>DS</sub> =-48V, V <sub>GS</sub> =0V, T <sub>J</sub> =55°C	---	---	5	uA
Gate-Source Leakage Current	I <sub>GSS</sub>	V <sub>GS</sub> =±20V, V <sub>DS</sub> =0V	---	---	±100	nA
Forward Transconductance	g <sub>fs</sub>	V <sub>DS</sub> =-4.5V, I <sub>D</sub> =-9A	---	20	---	S
Gate Resistance	R <sub>g</sub>	V <sub>DS</sub> =0V, V <sub>GS</sub> =0V, f=1MHz	---	7	---	Ω
Total Gate Charge	Q <sub>g</sub>	V <sub>DS</sub> =-30V, V <sub>GS</sub> =-10V, I <sub>D</sub> =-9A	---	36	---	nC
Gate-Source Charge	Q <sub>gs</sub>		---	6.9	---	
Gate-Drain Charge	Q <sub>gd</sub>		---	8.2	---	
Turn-On Delay Time	T <sub>d(on)</sub>	V <sub>DD</sub> =-30V, V <sub>GS</sub> =-10V, R <sub>G</sub> =3.3Ω, I <sub>D</sub> =-9A	---	12	---	ns
Rise Time	T <sub>r</sub>		---	14	---	
Turn-Off Delay Time	T <sub>d(off)</sub>		---	38	---	
Fall Time	T <sub>f</sub>		---	15	---	
Input Capacitance	C <sub>iss</sub>	V <sub>DS</sub> =-30V, V <sub>GS</sub> =0V, f=1MHz	---	1920	---	pF
Output Capacitance	C <sub>oss</sub>		---	120	---	
Reverse Transfer Capacitance	C <sub>rss</sub>		---	100	---	

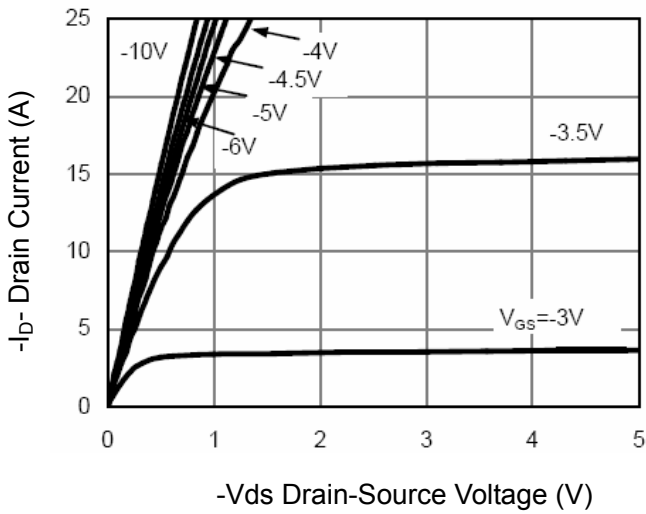
**Drain-Source Diode Characteristics**

Parameter	Symbol	Conditions	Min	Typ	Max	Unit
Continuous Source Current <sup>1</sup>	I <sub>S</sub>	V <sub>G</sub> =V <sub>D</sub> =0V, Force Current	---	---	-9	A
Pulsed Source Current <sup>2</sup>	I <sub>SM</sub>		---	---	-36	A
Diode Forward Voltage <sup>2</sup>	V <sub>SD</sub>	V <sub>GS</sub> =0V, I <sub>S</sub> =-1A, T <sub>J</sub> =25°C	---	---	-1	V

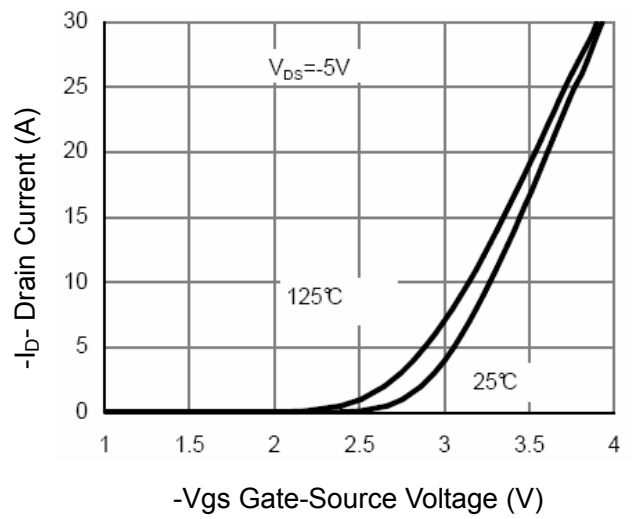
**Note:**

- 1.The data tested by surface mounted on a 1 inch<sup>2</sup> FR-4 board with 2OZ copper.
- 2.The data tested by pulsed, pulse width ≤ 300us, duty cycle ≤ 2%
- 3.The EAS data shows Max. rating. The test condition is V<sub>DD</sub>=-30V, V<sub>GS</sub>=-10V, L=0.5mH
- 4.The power dissipation is limited by 150°C junction temperature

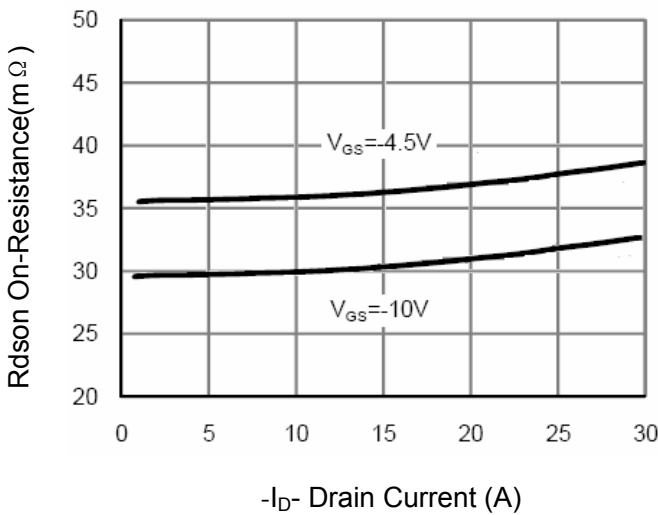
**Typical Characteristics**



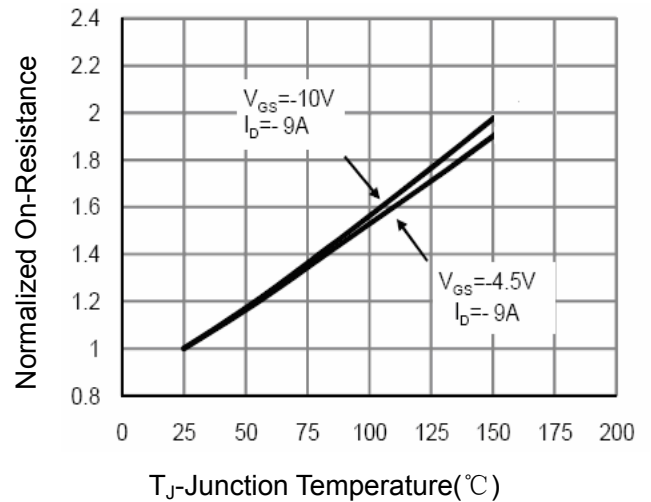
**Figure 1 Output Characteristics**



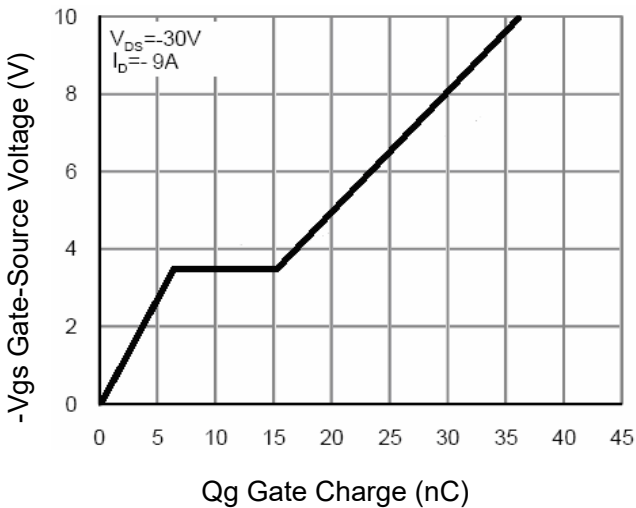
**Figure 2 Transfer Characteristics**



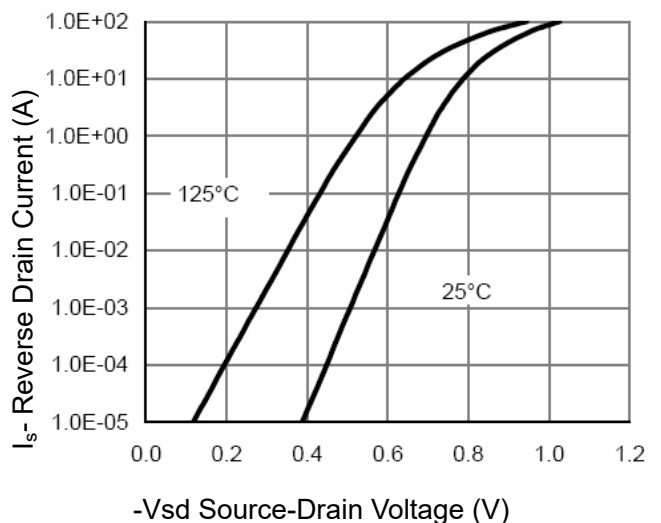
**Figure 3 Rdson- Drain Current**



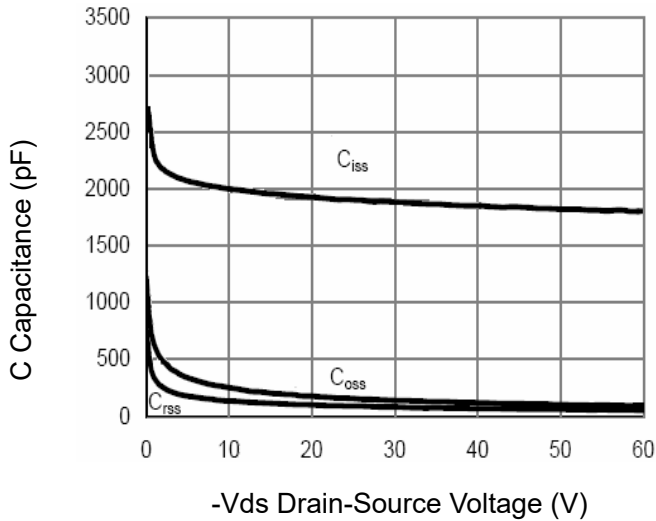
**Figure 4 Rdson-Junction Temperature**



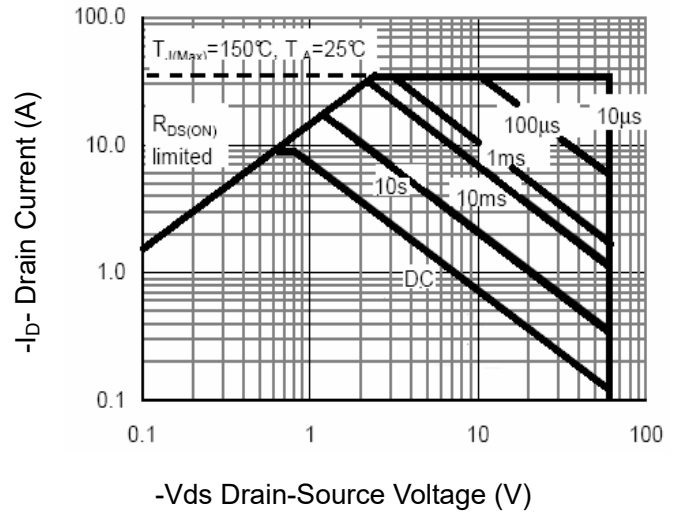
**Figure 5 Gate Charge**



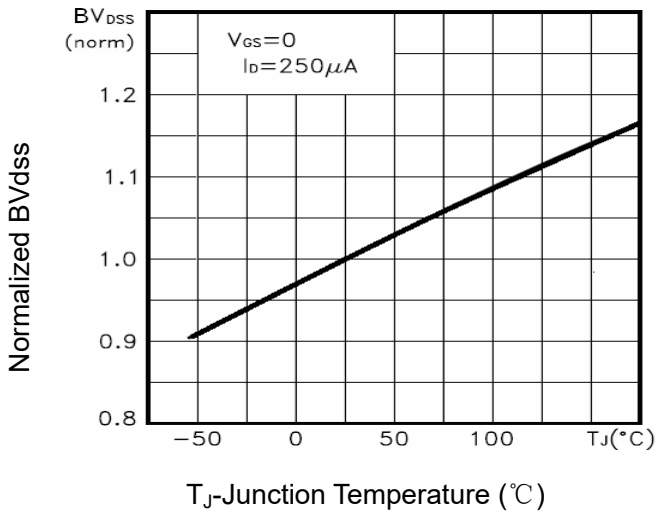
**Figure 6 Source- Drain Diode Forward**



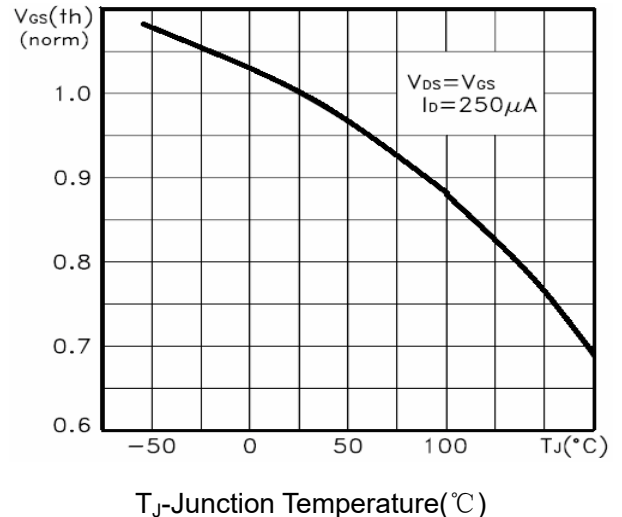
**Figure 7 Capacitance vs Vds**



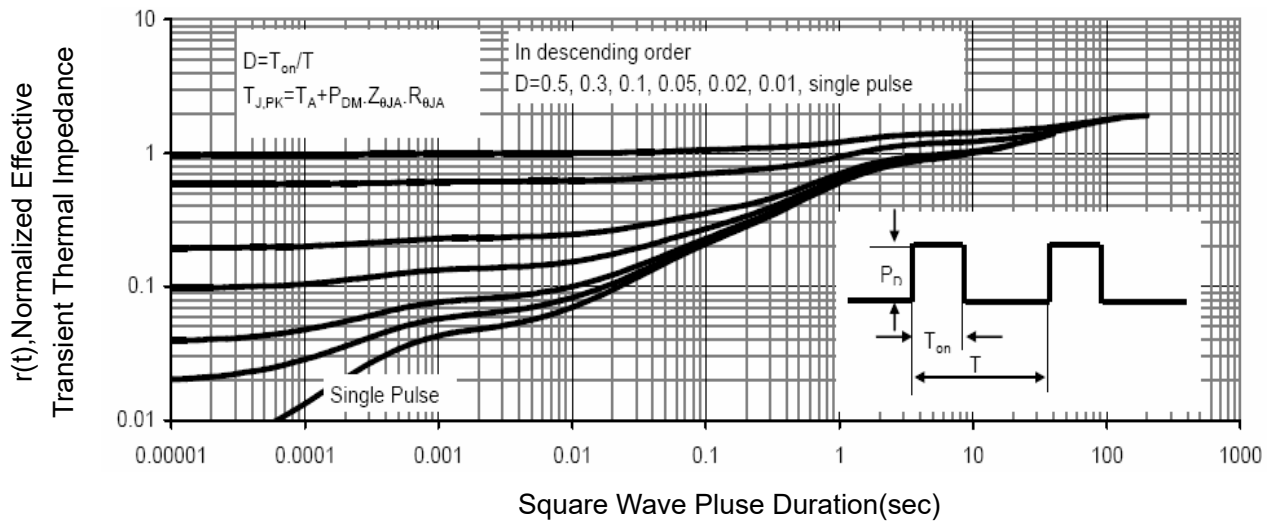
**Figure 8 Safe Operation Area**



**Figure 9 BV<sub>DSS</sub> vs Junction Temperature**

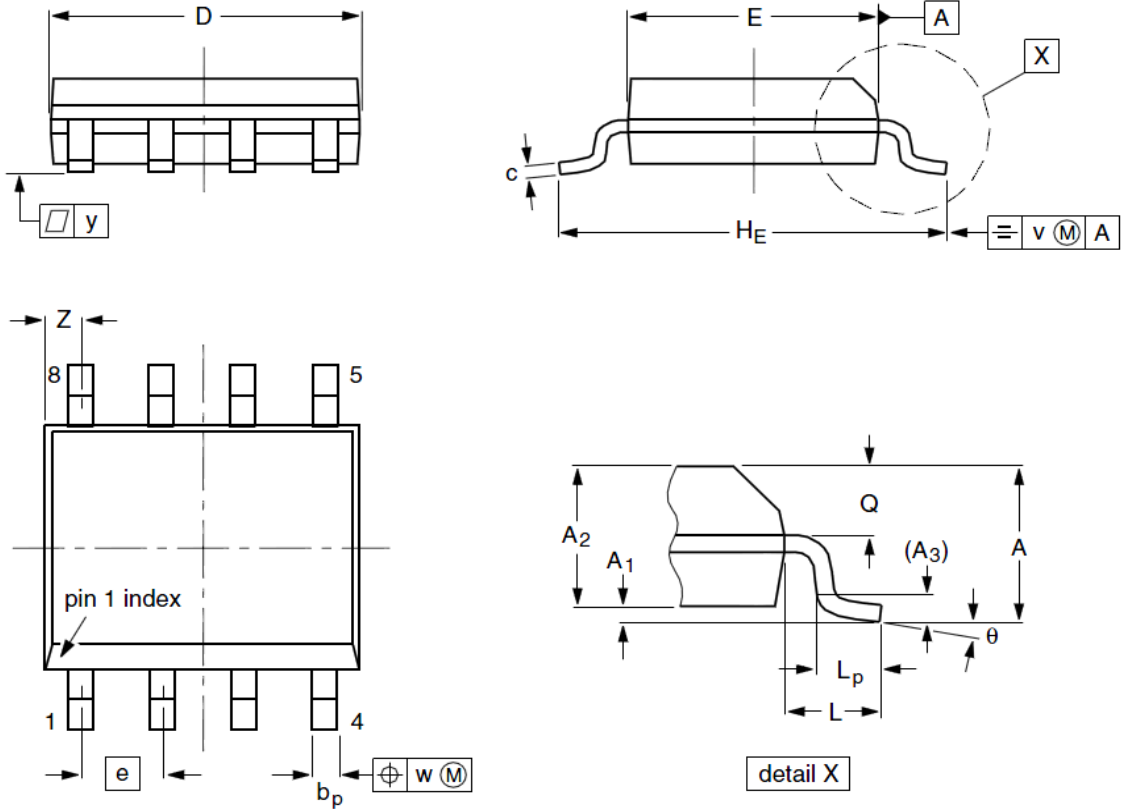


**Figure 10 V<sub>GS(th)</sub> vs Junction Temperature**



**Figure 11 Normalized Maximum Transient Thermal Impedance**

**SOP-8 Package Outline Dimensions**



Symbol	Dimensions (unit:mm)			Symbol	Dimensions (unit:mm)		
	Min	Typ	Max		Min	Typ	Max
<b>A</b>	1.35	1.55	1.75	<b>A<sub>1</sub></b>	0.10	0.18	0.25
<b>A<sub>2</sub></b>	1.25	1.45	1.65	<b>A<sub>3</sub></b>	--	0.25	--
<b>b<sub>p</sub></b>	0.36	0.42	0.51	<b>c</b>	0.19	0.22	0.25
<b>D</b>	4.70	4.92	5.10	<b>E</b>	3.80	3.90	4.00
<b>e</b>	--	1.27	--	<b>H<sub>E</sub></b>	5.80	6.00	6.20
<b>L</b>	--	1.05	--	<b>L<sub>p</sub></b>	0.40	0.68	1.00
<b>Q</b>	0.60	0.65	0.73	<b>v</b>	--	0.25	--
<b>w</b>	--	0.25	--	<b>y</b>	--	0.10	--
<b>Z</b>	0.30	0.50	0.70	<b>θ</b>	0°		8°